

HPVFE Universal AC Drive



Important User Information

The examples and diagrams in this manual are included solely for illustrative purposes. Because of the many variables and requirements associated with any particular installation, Solcom&hapn (shanghai) electric. Cannot assume responsibility or liability for actual use based on the examples and diagrams.

No patent liability is assumed by Solcom&hapn (shanghai) electric. with respect to use of information, circuits, equipment, or software described in this manual.

Reproduction of the contents of this manual, in whole or in part, without written permission of Solcom&hapn (shanghai) electric. is prohibited.

Throughout this manual, when necessary we use notes to make you aware of safety considerations.



WARNING: Identifies information about practices or circumstances that can cause an explosion in a hazardous environment, which may lead to personal injury or death, property damage, or economic loss.

Important: Identifies information that is critical for successful application and understanding of the product.



ATTENTION: Identifies information about practices or circumstances that can lead to personal injury or death, property damage, or economic loss. Attentions help you:

- identify a hazard
 - avoid the hazard
 - recognize the consequences
-



Shock Hazard labels may be located on or inside the equipment (e.g., drive or motor) to alert people that dangerous voltage may be present.



Burn Hazard labels may be located on or inside the equipment (e.g., drive or motor) to alert people that surfaces may be at dangerous temperatures.

Table of Contents

Preface Overview	1
Who Should Use this Manual.....	1
Manual Conventions.....	1
Drive Frame Sizes.....	2
General Precautions.....	2
Catalog Number Explanation.....	3
Chapter 1 Installation/Wiring	4
Opening the Cover.....	4
Mounting Considerations.....	5
AC Supply Source Considerations.....	6
General Grounding Requirements.....	7
Fuses and Circuit Breakers.....	9
Power Wiring.....	10
I/O Wiring Recommendations.....	13
Start and Speed Reference Control.....	20
EMC Instructions.....	22
Chapter2 Start Up	25
Prepare For Drive Start-Up.....	25
Integral Keypad.....	27
Viewing and Editing Parameters.....	28
Chapter 3 Programming and Parameters	30
About Parameters.....	30
Parameter Organization.....	31
Parameter Cross Reference - by Name.....	60
Chapter 4 Troubleshooting	61
Drive Status.....	61
Faults.....	61
Fault Descriptions.....	63
Common Symptoms and Corrective Actions.....	65
Appendix A Supplemental Drive Information	68
Drive, Fuse & Circuit Breaker Ratings.....	68
Specifications.....	69
Appendix B Accessories and Dimensions	73
Product Selection.....	73
Product Dimensions.....	75
Appendix C RS485 (DSI) Protocol	77
Network Wiring.....	77
Parameter Configuration.....	78
Supported Modbus Function Codes.....	78
Writing (06) Logic Command Data.....	79
Writing (06) Reference.....	80

Reading (03) Logic Status Data.....	80
Reading (03) Feedback.....	81
Reading (03) Drive Error Codes.....	81
Reading (03) and Writing (06) Drive Parameters.....	82
Appendix D RJ45 DSI Splitter Cable	83
Connectivity Guidelines.....	83
DSI Cable Accessories.....	83
Connecting an RS-485 Network.....	84
Index.....	85

Preface Overview

The purpose of this manual is to provide you with the basic information needed to install, start-up and troubleshoot the HPVFE Adjustable Frequency AC Drive.

For information on...	See page...
Who Should Use this Manual?	P-1
Reference Materials	P-1
Manual Conventions	P-2
Drive Frame Sizes	P-2
General Precautions	P-3
Catalog Number Explanation	P-4

Who Should Use this Manual

This manual is intended for qualified personnel. You must be able to program and operate Adjustable Frequency AC Drive devices. In addition, you must have an understanding of the parameter settings and functions.

Manual Conventions

- In this manual we refer to the HPVFE Adjustable Frequency AC Drive as: drive, HPVFE or HPVFE Drive.
- Parameter numbers and names are shown in this format:

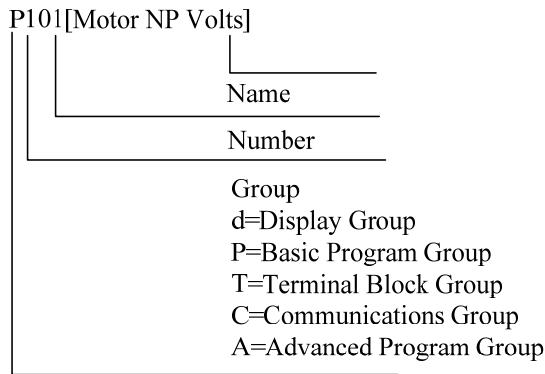

- The following words are used throughout the manual to describe an action:

Word	Meaning
Can	Possible, able to do something
Cannot	Not possible, not able to do something
May	Permitted, allowed
Must	Unavoidable, you must do this
Shall	Required and necessary
Should	Recommended
Should Not	Not Recommended

Drive Frame Sizes

Similar HPVFE drive sizes are grouped into frame sizes to simplify spare parts ordering, dimensioning, etc. A cross-reference of drive catalog numbers and their respective frame sizes is provided in [Appendix B](#).

General Precautions



ATTENTION: To avoid an electric shock hazard, verify that the voltage on the bus capacitors has discharged before performing any work on the drive. Measure the DC bus voltage at the –DC and +DC terminals on the Power Terminal Block (refer to [Chapter 1](#) Power Terminal descriptions). The voltage must be zero.

Darkened LEDs or a darkened LCD display is not an indication that capacitors have discharged to safe voltage levels.



ATTENTION: Only qualified personnel familiar with adjustable frequency AC drives and associated machinery should plan or implement the installation, start-up and subsequent maintenance of the system. Failure to comply may result in personal injury and/or equipment damage.



ATTENTION: This drive contains ESD (Electrostatic Discharge) sensitive parts and assemblies. Static control precautions are required when installing, testing, servicing or repairing this assembly. Component damage may result if ESD control procedures are not followed.



ATTENTION: An incorrectly applied or installed drive can result in component damage or a reduction in product life. Wiring or application errors, such as, undersizing the motor, incorrect or inadequate AC supply, or excessive ambient temperatures may result in malfunction of the system.



ATTENTION: The bus regulator function is extremely useful for preventing nuisance overvoltage faults resulting from aggressive decelerations, overhauling loads, and eccentric loads. However, it can also cause either of the following two conditions to occur.

1. Fast positive changes in input voltage or imbalanced input voltages can cause uncommanded positive speed changes;
2. Actual deceleration times can be longer than commanded deceleration times.

However, a “Stall Fault” is generated if the drive remains in this state for 1 minute. If this condition is unacceptable, the bus regulator must be disabled (see parameter [A441](#)). In addition, installing a properly sized dynamic brake resistor will provide equal or better performance in most cases.

Catalog Number Explanation

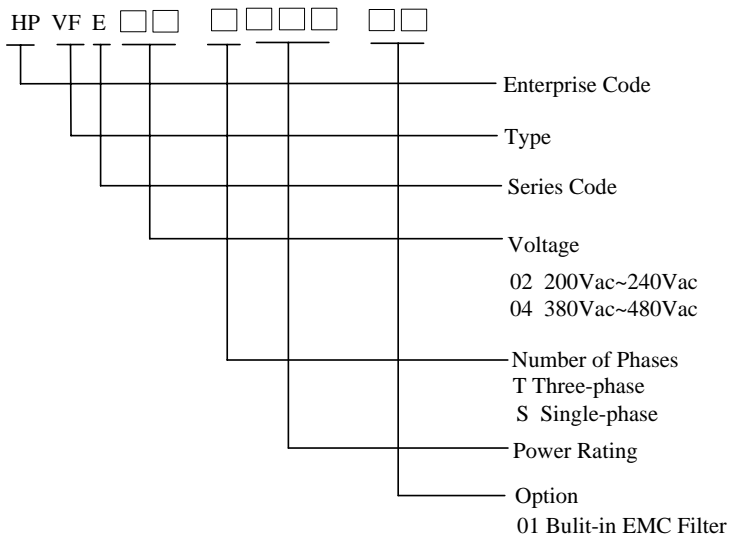

Drive Ratings				Catalog Number	Frame	Size	
Input Voltage	kW	HP	Output Current(A)	Panel Mount		W × H × D	
240V 50/60Hz 1- phase	0.2	0.25	1.6	HPVFE02S0D2	A	72 × 185.5 × 143.5	
	0.4	0.5	2.5	HPVFE02S0D4			
	0.75	1	4.2	HPVFE02S0D75			
	1.5	2	8	HPVFE02S1D5	B	100 × 174 × 145	
	2.2	3	11	HPVFE02S2D2			
240V 50/60Hz 1- phase ,with filter ⁽¹⁾	0.2	0.25	1.6	HPVFE02S0D201	A	72 × 185.5 × 143.5	
	0.4	0.5	2.5	HPVFE02S0D401			
	0.75	1	4.2	HPVFE02S0D7501			
		1.5	2	8	HPVFE02S1D501	B	100 × 174 × 145
		2.2	3	11	HPVFE02S2D201		
240V 50/60Hz 3- phase	0.2	0.25	1.6	HPVFE02T0D2	A	72 × 185.5 × 143.5	
	0.4	0.5	2.5	HPVFE02T0D4			
	0.75	1	4.2	HPVFE02T0D75			
	1.5	2	8	HPVFE02T1D5			
		2.2	3	12	HPVFE02T2D2	B	100 × 174 × 145
		3.7	5	17.5	HPVFE02T3D7		
		5.5	7.5	25	HPVFE02T5D5		
		7.5	10	33	HPVFE02T7D5		
480V 50/60Hz 3- phase	0.4	0.5	1.5	HPVFE04T0D4	A	72 × 185.5 × 143.5	
	0.75	1	2.5	HPVFE04T0D75			
	1.5	2	4.2	HPVFE04T1D5			
	2.2	3	6	HPVFE04T2D2			
		3.7	5	8.7	HPVFE04T3D7	B	100 × 174 × 145
		5.5	7.5	13	HPVFE04T5D5		
		7.5	10	18	HPVFE04T7D5		
		11	15	24	HPVFE04T11		
480V 50/60Hz 3- phase with filter ⁽¹⁾	0.4	0.5	1.5	HPVFE04T0D401	A	72 × 185.5 × 143.5	
	0.75	1.0	2.5	HPVFE04T0D7501			
	1.5	2.0	4.2	HPVFE04T1D501			
		2.2	3.0	6.0	HPVFE04T2D201	B	100 × 174 × 145
		3.7	5.0	8.7	HPVFE04T3D701		
		5.5	7.5	13.0	HPVFE04T5D501		
		7.5	10.0	18.0	HPVFE04T7D501		
		11.0	15.0	24.0	HPVFE04T1101		

Additional accessories, options and adapters are available. See [Appendix B](#) for details.

Chapter 1 Installation/Wiring

This chapter provides information on mounting and wiring the HPVFE Drive.

For information on...	See page	For information on...	See page
Opening the Cover	1-1	Fuses and Circuit Breakers	1-7
Mounting Considerations	1-2	Power Wiring	1-9
AC Supply Source Considerations	1-3	I/O Wiring Recommendations	1-13
General Grounding Requirements	1-5	EMC Instructions	1-21

Most start-up difficulties are the result of incorrect wiring. Every precaution must be taken to assure that the wiring is done as instructed. All items must be read and understood before the actual installation begins.

1. Press and hold in the tabs on each side of the cover.
2. Pull the cover out and up to release.



ATTENTION: The following information is merely a guide for proper installation. Rockwell Automation, Inc. cannot assume responsibility for the compliance or the noncompliance to any code, national, local or otherwise for the proper installation of this drive or associated equipment. A hazard of personal injury and/or equipment damage exists if codes are ignored during installation.

Opening the Cover

1. Press and hold in the tabs on each side of the cover.
2. Pull the cover out and up to release.

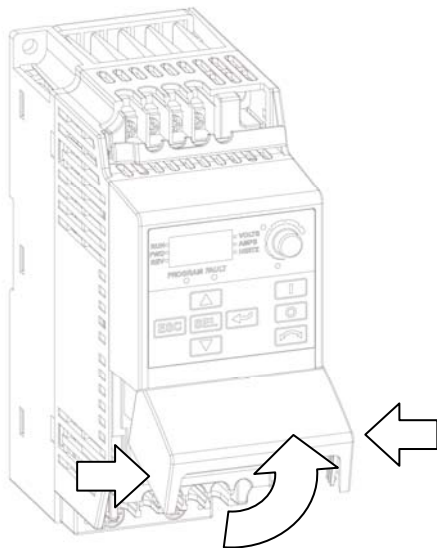

Mounting Considerations

- Mount the drive upright on a flat, vertical and level surface.
- Install on 35 mm DIN Rail (for frames A and B).

or

- Install with screws.

Table 1.A Screw Mounting Recommendations

Minimum Panel Thickness	Screw Size	Mounting Torque
1.9 mm (0.0747 in.)	M4 (#8-32)	1.56-1.96 N-m (14-17 lb.-in.)

- Protect the cooling fan by avoiding dust or metallic particles.
- Do not expose to a corrosive atmosphere.
- Protect from moisture and direct sunlight.

Minimum Mounting Clearances

Refer to [Appendix B](#) for mounting dimensions.

Ambient Operating Temperatures

Table 1.B Enclosure and Clearance Requirements

Horizontal Clearance between drives	Ambient Temperature	
	Minimum	Maximum
0 mm and greater	-10°C (14°F)	40°C (104°F)
25 mm and greater	-10°C (14°F)	50°C (122°F)

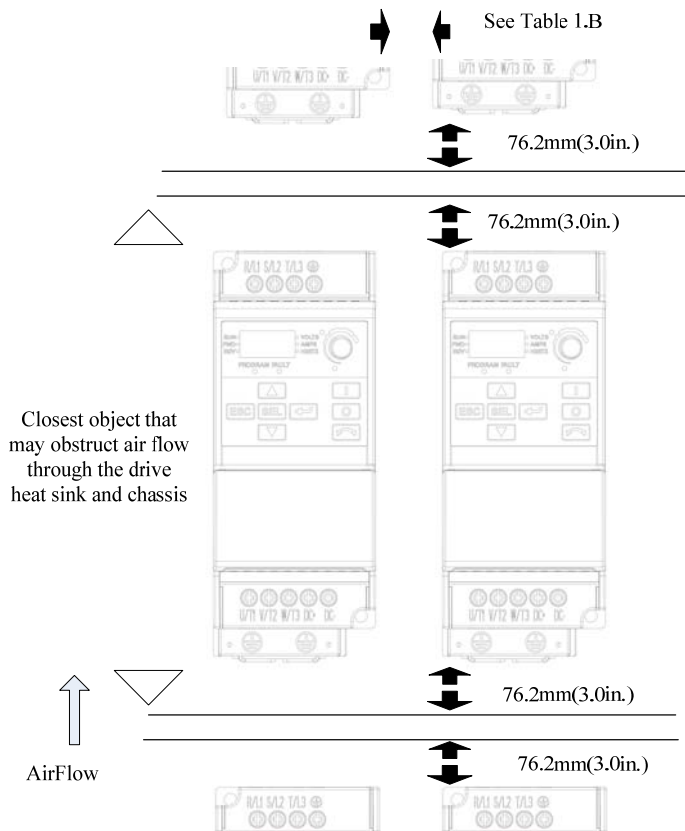

Drive enclosure is rated IP20, NEMA/UL Type Open.

Storage

- Store within an ambient temperature range of -40° to $+85^{\circ}\text{C}$.
- Store within a relative humidity range of 0% to 95%, non-condensing.
- Do not expose to a corrosive atmosphere.

AC Supply Source Considerations

Ungrounded Distribution Systems



ATTENTION: HPVFE drives contain protective MOVs that are referenced to ground. These devices must be disconnected if the drive is installed on an ungrounded or resistive grounded distribution system.

Disconnecting MOVs

To prevent drive damage, the MOVs connected to ground shall be disconnected if the drive is installed on an ungrounded distribution system where the line-to-ground voltages on any phase could exceed 125% of the nominal line-to-line voltage. To disconnect these devices, remove the jumper shown in the Figures 1.1 and 1.2.

1. Turn the screw counterclockwise to loosen.
2. Pull the jumper completely out of the drive chassis.
3. Tighten the screw to keep it in place.

Figure 1.1 Jumper Location (Frame A shown)

Important: Tighten screw after jumper removal.

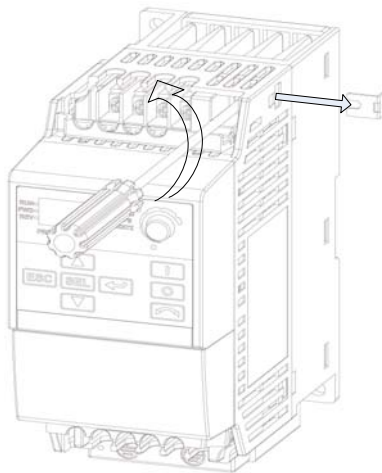
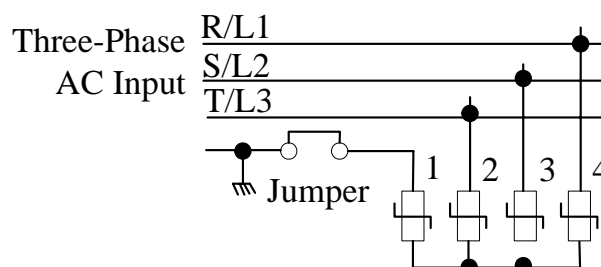

Fig1.2 Phase to Ground MOV Removal



Input Power Conditioning

The drive is suitable for direct connection to input power within the rated voltage of the drive (see [Appendix A](#)). Listed in [Table 1.C](#) are certain input power conditions which may cause component damage or reduction in product life. If any of the conditions exist, as described in [Table 1.C](#), install one of the devices listed under the heading Corrective Action on the line side of the drive.

Important: Only one device per branch circuit is required. It should be mounted closest to the branch and sized to handle the total current of the branch circuit.

Table 1.C Input Power Conditions

Input Power Condition	Corrective Action
Low Line Impedance (less than 1% line reactance)	<ul style="list-style-type: none"> • Install Line Reactor(1) • or Isolation Transformer
Greater than 120 kVA supply transformer	
Line has power factor correction capacitors	
Line has frequent power interruptions	
Line has intermittent noise spikes in excess of 6000V (lightning)	
Phase to ground voltage exceeds 125% of normal line to line voltage	<ul style="list-style-type: none"> • Remove MOV jumper to ground. • or Install Isolation Transformer with grounded secondary if necessary.
Ungrounded distribution system	

(1) Refer to [Appendix B](#) for accessory ordering information.

General Grounding Requirements

The drive Safety Ground (PE) must be connected to system ground. Ground impedance must conform to the requirements of national and local industrial safety regulations and/or electrical codes. The integrity of all ground connections should be periodically checked.

Figure 1.3 Typical Grounding

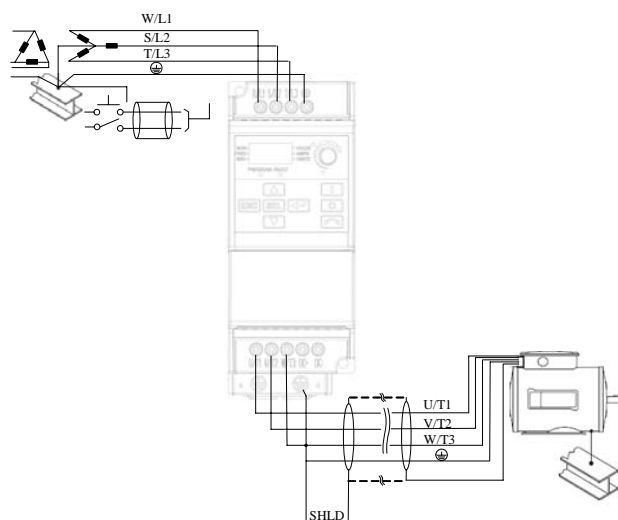

Ground Fault Monitoring

If a system ground fault monitor (RCD) is to be used, only Type B (adjustable) devices should be used to avoid nuisance tripping.

Safety Ground - (PE)

This is the safety ground for the drive that is required by code. One of these points must be connected to adjacent building steel (girder, joist), a floor ground rod or bus bar. Grounding points must comply with national and local industrial safety Regulations and/or electrical codes.

MotorGround

The motor ground must be connected to one of the ground terminals on the drive.

Shield Termination - SHLD

Either of the safety ground terminals located on the power terminal block provides a grounding point for the motor cable shield. The **motor cable** shield connected to one of these terminals (drive end) should also be connected to the motor frame (motor end). Use a shield terminating or EMI clamp to connect the shield to the safety ground terminal. The conduit box option may be used with a cable clamp for a grounding point for the cable shield.

When shielded cable is used for **control and signal wiring**, the shield should be grounded at the source end only, not at the drive end.

RFI Filter Grounding

Using single phase drives with integral filter, or an external filter with any drive rating, may result in relatively high ground leakage currents. Therefore, the **filter must only be used in installations with grounded AC supply systems and be permanently installed and solidly grounded** (bonded) to the building power distribution ground. Ensure that the incoming supply neutral is solidly connected (bonded) to the same building power distribution ground. Grounding must not rely on flexible cables and should not include any form of plug or socket that would permit inadvertent disconnection. Some local codes may require redundant ground connections. The integrity of all connections should be periodically checked.

Fuses and Circuit Breakers

The HPVFE does not provide branch short circuit protection. This product should be installed with either input fuses or an input circuit breaker. National and local industrial safety regulations and/or electrical codes may determine additional requirements for these installations.



ATTENTION: To guard against personal injury and/or equipment damage caused by improper fusing or circuit breaker selection, use only the recommended line fuses/circuit breakers specified in this section.

Fusing

The HPVFE has been UL tested and approved for use with input fuses. The ratings in the table that follows are the maximum recommended values for use with each drive rating. The devices listed in this table are provided to serve as a guide.

Bulletin 140M (Self-Protected Combination Controller)/UL489 Circuit Breakers

When using Bulletin 140M or UL489 rated circuit breakers, the guidelines listed below must be followed in order to meet the NEC requirements for branch circuit protection.

- Bulletin 140M can be used in single and group motor applications.
- Bulletin 140M can be used up stream from the drive **without** the need for fuses.

Power Wiring



ATTENTION: National Codes and standards (NEC, VDE, BSI, etc.) and local codes outline provisions for safely installing electrical equipment. Installation must comply with specifications regarding wire types, conductor sizes, branch circuit protection and disconnect devices. Failure to do so may result in personal injury and/or equipment damage.



ATTENTION: To avoid a possible shock hazard caused by induced voltages, unused wires in the conduit must be grounded at both ends. For the same reason, if a drive sharing a conduit is being serviced or installed, all drives using this conduit should be disabled. This will help minimize the possible shock hazard from “cross coupled” power leads.

Motor Cable Types Acceptable for 200-600 Volt Installations

General

A variety of cable types are acceptable for drive installations. For many installations, unshielded cable is adequate, provided it can be separated from sensitive circuits. As an approximate guide, allow a spacing of 0.3 meters (1 foot) for every 10 meters (32.8 feet) of length. In all cases, long parallel runs must be avoided. Do not use cable with an insulation thickness less than 15 mils (0.4 mm/0.015 in.). Do not route more than three sets of motor leads in a single conduit to minimize “cross talk”. If more than three drive/motor connections per conduit are required, shielded cable must be used.

UL installations in 50°C ambient must use 600V, 75°C or 90°C wire.

UL installations in 40°C ambient should use 600V, 75°C or 90°C wire.

Use copper wire only. Wire gauge requirements and recommendations are based on 75 degree C. Do not reduce wire gauge when using higher temperature wire.

Unshielded

THHN, THWN or similar wire is acceptable for drive installation in dry environments provided adequate free air space and/or conduit fill rates limits are provided. **Do not use THHN or similarly coated wire in wet areas.** Any wire chosen must have a minimum insulation thickness of 15 mils and should not have large variations in insulation concentricity.

Shielded

Location	Rating/Type	Description
Standard (Option 1)	600V, 75°C or 90°C (167°F or 194°F) RHH/RHW-2 Belden 29501-29507 or equivalent	<ul style="list-style-type: none"> • Four tinned copper conductors with XLPE insulation • Foil shield and tinned copper drain wire with 85% braid coverage • PVC jacket
Standard (Option 2)	Tray rated 600V, 75°C or 90°C (167°F or 194°F) RHH/RHW-2 Shawflex 2ACD/3ACD or equivalent	<ul style="list-style-type: none"> • Three tinned copper conductors with XLPE insulation • 5 mil single helical copper tape (25% overlap min.) with three bare copper grounds in contact with shield • PVC jacket
Class I & II; Division I & II	Tray rated 600V, 75°C or 90°C (167°F or 194°F) RHH/RHW-2	<ul style="list-style-type: none"> • Three tinned copper conductors with XLPE insulation • 5 mil single helical copper tape (25% overlap min.) with three bare copper grounds in contact with shield • PVC copper grounds on #10 AWG and smaller

Reflected Wave Protection

The drive should be installed as close to the motor as possible. Installations with long motor cables may require the addition of external devices to limit voltage reflections at the motor (reflected wave phenomena). See [Table 1.E](#) for recommendations.

The reflected wave data applies to all frequencies 2 to 10 kHz.

For 240V ratings, reflected wave effects do not need to be considered.

Table 1.E Maximum Cable Length Recommendations

Reflected Wave		
380-480V Ratings	Motor Insulation Rating	Motor Cable Only ⁽¹⁾
	1000 Vp-p	15 meters (49 feet)
	1200 Vp-p	40 meters (131 feet)
	1600 Vp-p	170 meters (558 feet)

⁽¹⁾Longer cable lengths can be achieved by installing devices on the output of the drive. Consult factory for recommendations.

Output Disconnect

The drive is intended to be commanded by control input signals that will start and stop the motor. A device that routinely disconnects then reapplies output power to the motor for the purpose of starting and stopping the motor should not be used. If it is necessary to disconnect power to the motor with the drive outputting power, an auxiliary contact should be used to simultaneously disable drive control run commands.

Power Terminal Block

The drive utilizes a finger guard over the power wiring terminals.

To remove:

1. Press in and hold the locking tab.
2. For the finger guard on the top of the drive, slide it down and out.
For the finger guard at the bottom of the drive, slide it up and out.

Replace the finger guard when wiring is complete.

Figure 1.4 Power Terminal Block

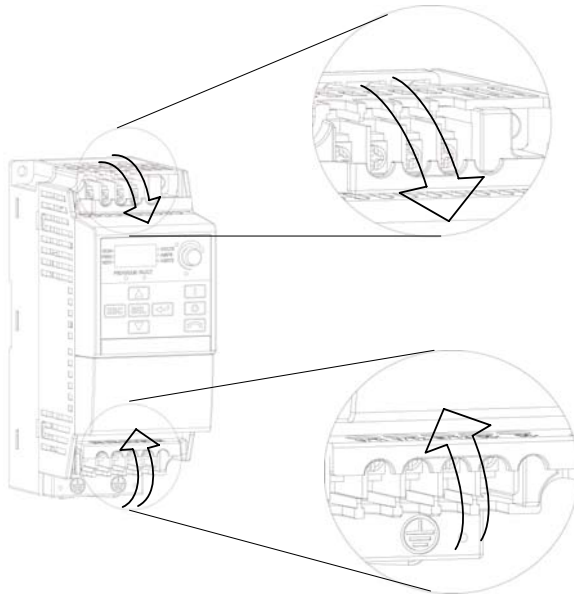

Terminal	Description
R/L1, S/L2	1-Phase Input
R/L1, S/L2, T/L3	3-Phase Input
P1(1), P2(1)	DC Bus Inductor Connection (Frame C drives only.) The Frame C drive is shipped with a jumper between Terminals P1 and P2. Remove this jumper only when a DC Bus Inductor will be connected. Drive will not power up without a jumper or inductor connected.
U/T1	To Motor U/T1
V/T2	To Motor V/T2
W/T3	To Motor W/T3



Switch any two motor leads to change forward direction.

Terminal	Description
DC+, DC-	DC Bus Connection
BR+ ⁽¹⁾ , BR- ⁽¹⁾	Dynamic Brake Resistor Connection
	Safety Ground - PE

(1)For Frame C only [5.5 kW (7.5 HP) ratings and higher].

(2)Not applicable to 120 V, 1-Phase drives.

Table 1.F Power Terminal Block Specifications

Frame	Maximum Wire Size (1)	Minimum Wire Size ⁽¹⁾	Torque
A	3.3 mm ² (12 AWG)	0.8 mm ² (18 AWG)	1.4-1.6 N-m(12-14 lb.-in)
B	8.4 mm ² (8AWG)	0.8 mm ² (18AWG)	1.6-1.9 N-m(14-17 lb.-in)
C	13.3 mm ² (6 AWG)	3.3 mm ² (12 AWG)	2.7-3.2 N-m(24-28 lb.-in)

(1)Maximum/minimum sizes that the terminal block will accept - these are not recommendations.

Motor Start/Stop Precautions



ATTENTION: A contactor or other device that routinely disconnects and reapplies the AC line to the drive to start and stop the motor can cause drive hardware damage. The drive is designed to use control input signals that will start and stop the motor. If used, the input device must not exceed One operation per minute or drive damage can occur.



ATTENTION: The drive start/stop control circuitry includes solid-state components. If hazards due to accidental contact with moving machinery or unintentional flow of liquid, gas or solids exist, an additional hardwired stop circuit may be required to remove the AC line to the drive. When the AC line is removed, there will be a loss of any inherent regenerative braking effect that might be present - the motor will coast to a stop. An auxiliary braking method may be required.

I/O Wiring Recommendations

Important points to remember about I/O wiring:

- Always use copper wire.
- Wire with an insulation rating of 600V or greater is recommended.
- Control and signal wires should be separated from power wires by at least 0.3 meters (1 foot).

Important:I/O terminals labeled “Common” are not referenced to the safety ground (PE) terminal and are designed to greatly reduce common mode interference.



ATTENTION: Driving the 4-20mA analog input from a voltage source could cause component damage. Verify proper configuration prior to applying input signals.

Control Wire Types

Table 1.G Recommended Control and Signal Wire⁽¹⁾

Wire Type(s)	Description	Minimum Insulation Rating
Belden 8760/9460 (or equiv.)	0.8 mm ² (18 AWG), twisted pair, 100% shield with drain.	300V 60 degrees C
Belden 8770 (or equiv.)	0.8 mm ² (18 AWG), 3 conductor, shielded for remote pot only.	(140 degrees F)

(1)If the wires are short and contained within a cabinet which has no sensitive circuits, the use of shielded wire may not be necessary, but is always recommended.

I/O Terminal Block

Table 1.H I/O Terminal Block Specifications

Maximum Wire Size ⁽¹⁾	Minimum Wire Size ⁽¹⁾	Torque
1.3 mm ² (16 AWG)	0.2 mm ² (24 AWG)	0.5-0.8 N-m (4.4-7 lb.-in.)

(1)Maximum/minimum sizes that the terminal block will accept - these are not recommendations.



Maximum Control Wire Recommendations

Do not exceed control wiring length of 30 meters (100 feet). Control signal cable length is highly dependent on electrical environment and installation practices. To improve noise immunity, the I/O terminal block Common must be connected to ground terminal/protective earth. If using the RS485 (DSI) port, I/O Terminal 16 should also be connected to ground terminal/protective earth.

Figure 1.5 Control Wiring Block Diagram

(1) Important: I/O Terminal 01 is always a coast to stop input except when P106 [Start Source] is set to “3-Wire” control. In three wire control, I/O Terminal 01 is controlled by P107 [Stop Mode]. All other stop sources are controlled by P107 [Stop Mode]. **Important:** The drive is shipped with a jumper installed between I/O Terminals 01 and 11. Remove this jumper when using I/O Terminal 01 as a stop or enable input.

P106[Start Source]	Stop	I/O Terminal 01Stop
Keypad	Per P107	Coast
3-Wire	Per P107	Per P107
2-Wire	Per P107	Coast
RS485 Port	Per P107	Coast

(2) Two wire control shown. For three wire control use a momentary input  on I/O Terminal 02 to command a start. Use a maintained input  for I/O Terminal 03 to change direction.

	30V DC	125 V DC	240V DC
Resistive	3.0A	3.0A	3.0A
Inductive	0.5A	0.5A	0.5A

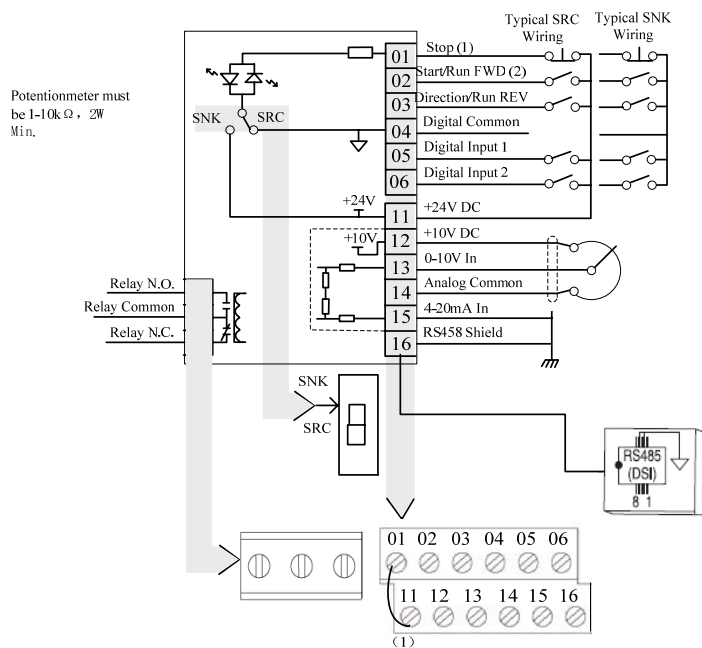

No.	Signal	Default	Description	Param.
R1	Relay N.O.	Fault	Normally open contact for output relay.	t221
R2	Relay Common	–	Common for output relay.	
R3	Relay N.C.	Fault	Normally closed contact for output relay.	t221
Sink/Source DIP Switch		Source (SRC)	Inputs can be wired as Sink (SNK) or Source (SRC) via DIP Switch setting.	
01	Stop (1)	Coast	The factory installed jumper or a normally closed input must be present for the drive to start.	P106.(1)
02	Start/Run FWD	Not Active	Command comes from the integral keypad by default. To disable reverse operation, see A095 [Reverse Disable].	P106, P107
02	Start/Run FWD	Not Active	Command comes from the integral keypad by default. To disable reverse operation, see A095 [Reverse Disable].	P106, P107,
03	Direction/Run REV	Not Active		P106, P107, A434
04	Digital Common	–	For digital inputs. Electronically isolated with digital inputs from analog I/O.	
05	Digital Input 1	Preset Freq	Program with t201 [Digital In1 Sel].	t201
06	Digital Input 2	Preset Freq	Program with t202 [Digital In2 Sel].	t202
11	+24V DC	–	Drive supplied power for digital inputs. Maximum output current is 100mA	

I/O Wiring Examples

No.	Signal	Default	Description	Param.
12	+10V DC	–	Drive supplied power for 0-10V external potentiometer. Maximum output current is 15mA.	P108
13	0-10V In (3)	Not Active	For external 0-10V input supply(input impedance = 100k ohm) or potentiometer wiper.	P108
14	Analog Common	–	For 0-10V In or 4-20mA In. Electronically isolated with analog inputs from digital I/O.	
15	4-20mA In (3)	Not Active	For external 4-20mA input supply(input impedance = 250 ohm).	P108
06	Digital Input 2	Preset Freq	Program with t202 [Digital In2 Sel].	t202
16	RS485 (DSI) Shield	–	Terminal should be connected to safety ground - PE when using the RS485 (DSI) communications port.	

(3)Only one analog frequency source may be connected at a time. If more than one reference is connected at the same time, an undetermined frequency reference will result.

I/O Wiring Examples

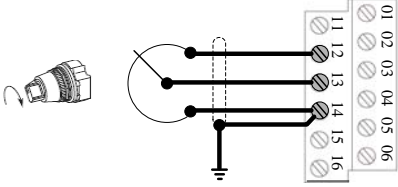
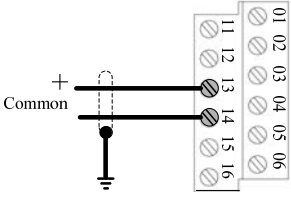
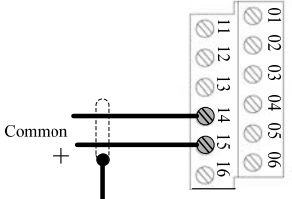
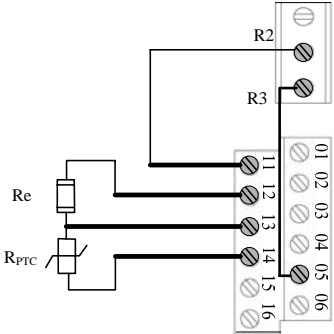
Input	Connection Example	
<p>Potentiometer</p> <p>1-10k Ohm Pot. Recommended (2 Watt minimum)</p>	<p>P108 [Speed Reference] = 2 "0-10V Input"</p> 	
<p>Analog Input</p> <p>0 to +10V, 100k ohm impedance 4-20 mA, 100 ohm impedance</p>	<p>Voltage</p> <p>P108 [Speed Reference] = 2 "0-10V Input"</p> 	<p>Current</p> <p>P108 [Speed Reference] = 3 "4-20mA Input"</p> 
<p>Analog Input, PTC For Drive Fault</p>	<p>Wire the PTC and External Resistor (typically matched to the PTC Hot Resistance) to I/O Terminals 12, 13, 14.</p> <p>Wire R2/R3 Relay Output (SRC) to I/O Terminals 5 & 11.</p> <p>t201 [Digital In1 Sel] = 3 "Aux Fault"</p> <p>t221 [Relay Out Sel] = 10 "Above Ang V"</p> <p>t222 [Relay Out Level] = % Voltage Trip</p>  <div style="border: 1px solid black; padding: 5px; width: fit-content; margin: 10px auto;"> $V_{\text{Trip}} = \frac{R_{\text{PTC}(\text{hot})}}{R_{\text{PTC}(\text{hot})} + R_e} \cdot 100$ </div>	

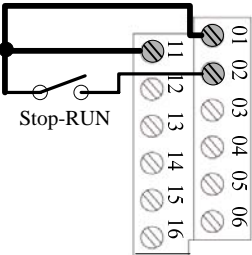
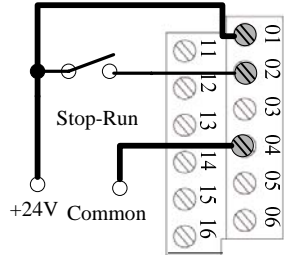
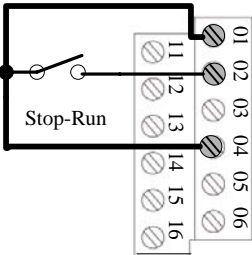
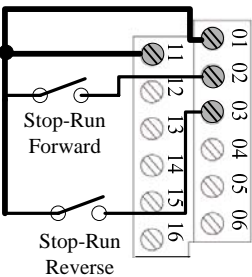
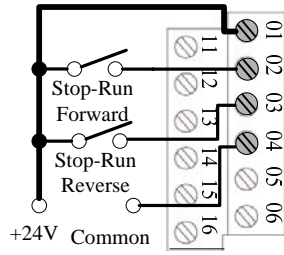
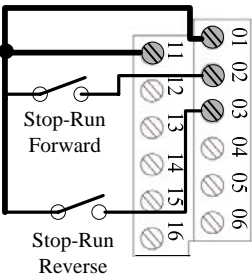
Input	Connection Example	
<p>2 Wire SRC Control - Non-Reversing</p> <p>P106 [Start Source] = 2, 3 or 4</p> <p>Input must be active for the drive to run.</p> <p>When input is opened, the drive will stop as specified by P107 [Stop Mode].</p> <p>If desired, a User Supplied 24V DC power source can be used. Refer to the “External Supply (SRC)” example.</p>	<p>Internal Supply (SRC)</p> 	<p>External Supply (SRC)</p>  <p>Each digital input draws 6mA</p>
<p>2 Wire SNK Control - Non-Reversing</p>	<p>Internal Supply (SNK)</p> 	
<p>2 Wire SRC Control - Run FWD/Run REV</p> <p>P106 [Start Source] = 2, 3 or 4</p> <p>Input must be active for the drive to run.</p> <p>When input is opened, the drive will stop as specified by P107 [Stop Mode].</p> <p>If both Run Forward and Run Reverse inputs are closed at the same time, an undetermined state could occur.</p>	<p>Internal Supply (SRC)</p> 	<p>External Supply (SRC)</p>  <p>Each digital input draws 6mA</p>
<p>2 Wire SNK Control - Run FWD/Run REV</p>	<p>Internal Supply (SNK)</p> 	

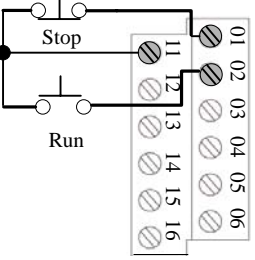
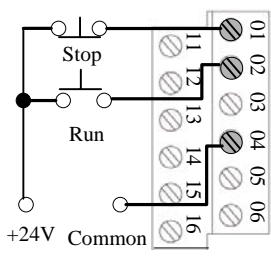
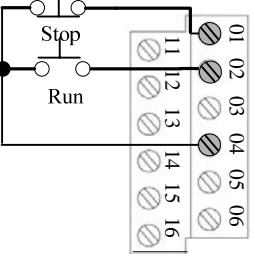
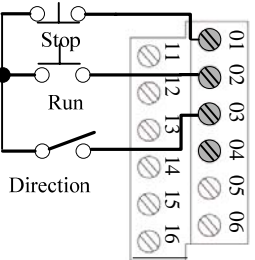
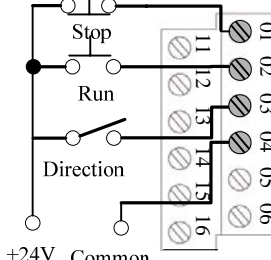
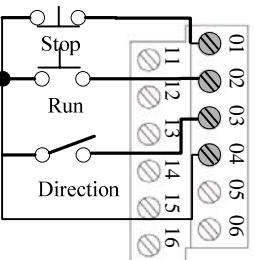
Input	Connection Example	
<p>3 Wire SRC Control - Non-Reversing</p> <p>P106 [Start Source] = 1</p> <p>A momentary input will start the drive. A stop input to I/O Terminal 01 will stop the drive as specified by P107 [Stop Mode].</p>	<p>Internal Supply (SRC)</p> 	<p>External Supply (SRC)</p>  <p>Each digital input draws 6mA</p>
<p>3 Wire SNK Control - Non-Reversing</p>	<p>Internal Supply (SNK)</p> 	
<p>3 Wire SRC Control - Reversing</p> <p>P106 [Start Source] = 1</p> <p>A momentary input will start the drive. A stop input to I/O Terminal 01 will stop the drive as specified by P107 [Stop Mode]. I/O Terminal 03 determines direction.</p>	<p>Internal Supply (SRC)</p> 	<p>External Supply (SRC)</p>  <p>Each digital input draws 6mA</p>
<p>3 Wire SNK Control - Reversing</p>	<p>Internal Supply (SNK)</p> 	

Typical Multiple Drive Connection Examples

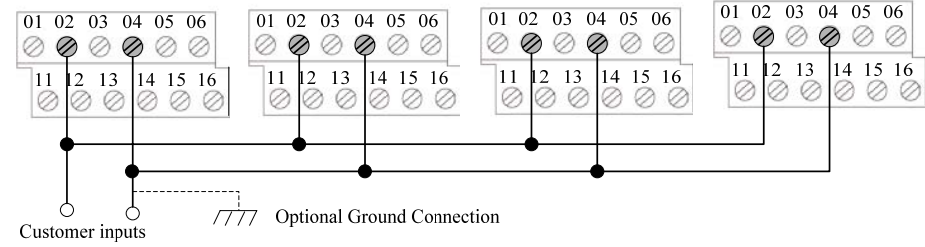
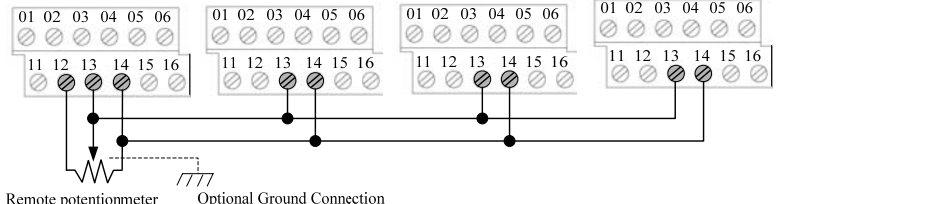
Input	Connection Example
<p>Multiple Digital Input Connections</p> <p>Customer Inputs can be wired per External Supply (SRC) examples on page 1-16.</p>	 <p>When connecting a single input such as Run, Stop, Reverse or Preset Speeds to multiple drives, it is important to connect I/O Terminal 04 common together for all drives. If they are to be tied into another common (such as earth ground or separate apparatus ground) only one point of the daisy chain of I/O Terminal 04 should be connected.</p> <p>ATTENTION: Digital inputs on multiple drives should not be tied together when using SNK (Internal Supply) mode. In SNK mode, if power is removed from one drive, inadvertent operation of other drives that share the same I/O Common connection may occur.</p>
<p>Multiple Analog Connections</p>	 <p>When connecting a single potentiometer to multiple drives it is important to connect I/O Terminal 14 common together for all drives. I/O Terminal 14 common and I/O Terminal 13 (potentiometer wiper) should be daisy-chained to each drive. All drives must be powered up for the analog signal to be read correctly.</p>

Start and Speed Reference Control

The drive speed command can be obtained from a number of different sources. The source is normally determined by P108 [Speed Reference]. However, when t201 or t202 Digital Inx Sel is set to option 2, 4, 5 or 6, and the digital input is active, t201 or t202 will override the speed reference commanded by P108 [Speed Reference]. See the chart below for the override priority.

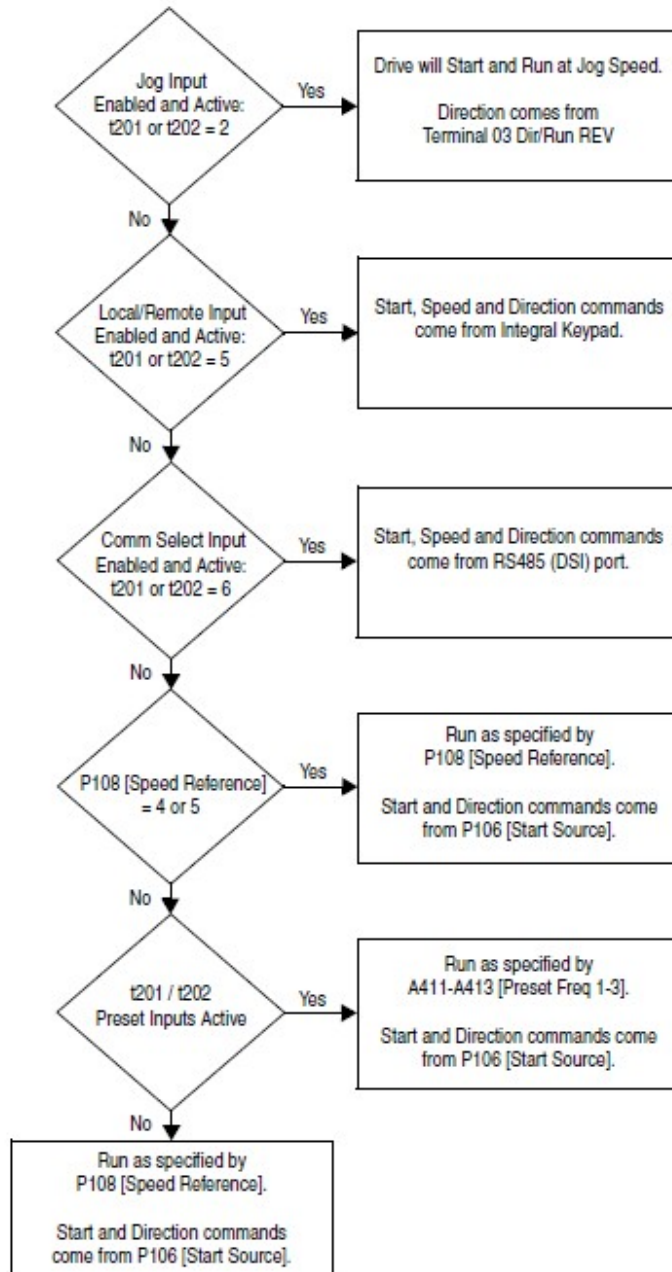

Accel/Decel Selection

The selection of Accel/Decel rates can be made through digital inputs, RS485 (DSI) communications and/or parameters.

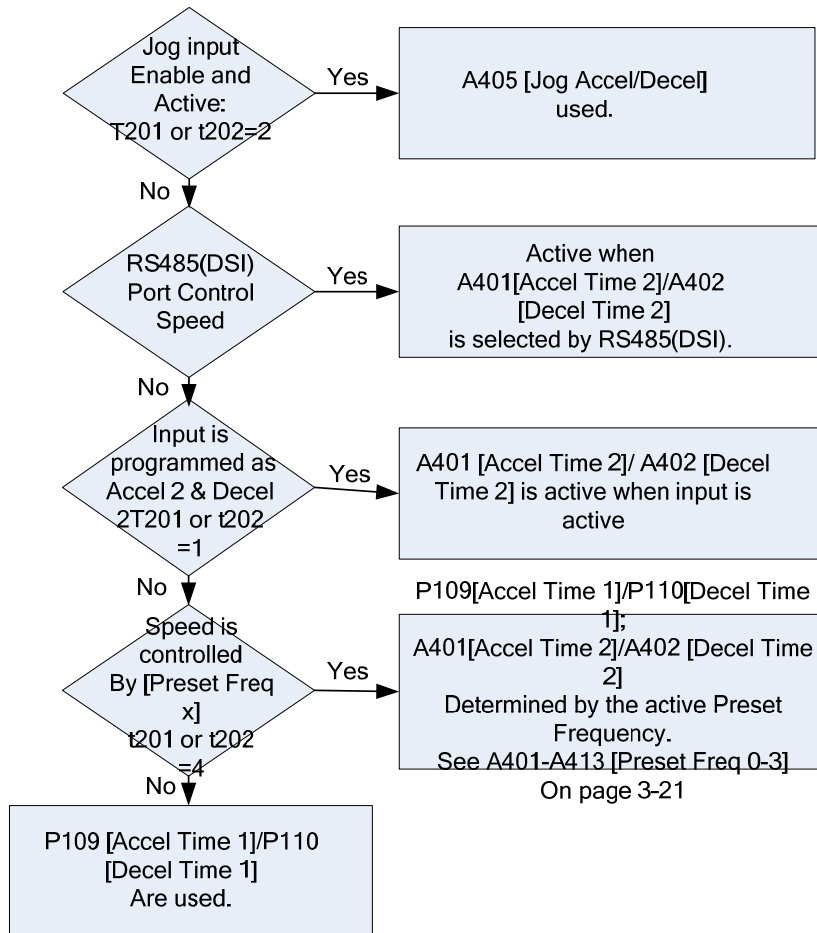

EMC Instructions

CE Conformity

Conformity with the Low Voltage (LV) Directive and Electromagnetic Compatibility (EMC) Directive has been demonstrated using harmonized European Norm (EN) standards published in the Official Journal of the European Communities. HPVFE Drives comply with the EN standards listed below when installed according to the User Manual.

CE Declarations of Conformity are available online at:

Low Voltage Directive (73/23/EEC)

- EN50178 Electronic equipment for use in power installations

EMC Directive (89/336/EEC)

- EN61800-3 Adjustable speed electrical power drive systems Part 3: EMC product standard including specific test methods.

General Notes

- The motor cable should be kept as short as possible in order to avoid electromagnetic emission as well as capacitive currents.
- Use of line filters in ungrounded systems is not recommended.
- Conformity of the drive with CE EMC requirements does not guarantee an entire machine installation complies with CE EMC requirements. Many factors can influence total machine/installation compliance.

Essential Requirements for CE Compliance

Conditions 1-3 listed below **must be** satisfied for HPVFE drives to meet the requirements of **EN61800-3**.

1. Grounding as described in [Figure 1.6](#). Refer to [page 1-6](#) for additional grounding recommendations.
2. Output power, control (I/O) and signal wiring must be braided, shielded cable with a coverage of 75% or better, metal conduit or equivalent attenuation.
3. Allowable cable length in [Table 1.I](#) is not exceeded.

Table 1.I Allowable Cable Length

Filter Type	EN61800-3 Second Environment	EN61800-3 First Environment Restricted Distribution ⁽²⁾	EN61800-3 First Environment Unrestricted Distribution ⁽³⁾
Integral, 240V	5 meters (16 feet)	5 meters (16 feet)	1 meter (3 feet)
Integral, 480V	10 meters (33 feet)	-	-
External - S Type ⁽¹⁾	5 meters (16 feet)	5 meters (16 feet)	1 meter (3 feet)
External - L Type ⁽¹⁾	100 meters (328 feet)	100 meters (328 feet)	25 meters (82 feet)

(1) Refer to [Appendix B](#) for details on optional external filters.

(2) Equivalent to EN55011 Class A.

(3) Equivalent to EN55011 Class B.

Figure 1.6 Connections and Grounding

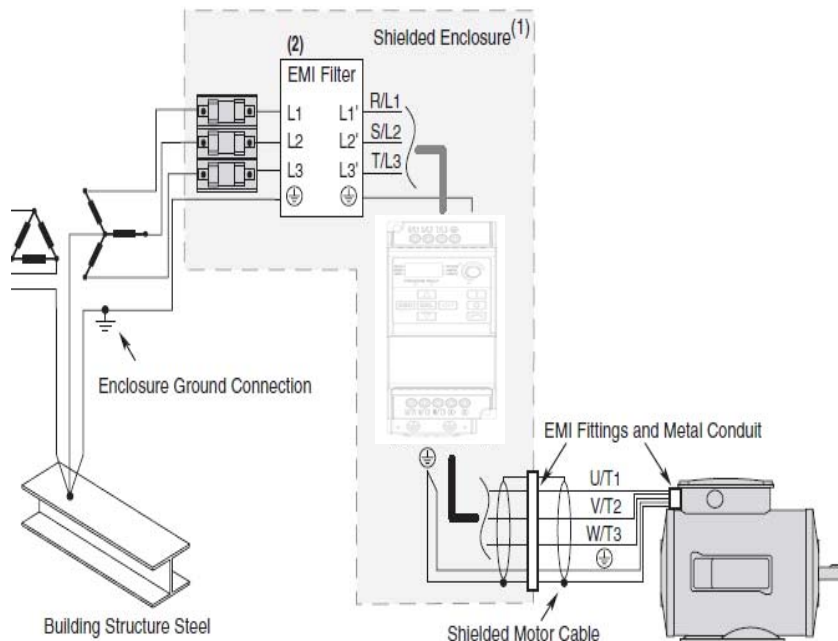

(1) First Environment Unrestricted Distribution installations require a shielded enclosure. Keep wire length as short as possible between the enclosure entry point and the EMI filter.

(2) Integral EMI filters are available on 240V, 1-Phase drives and 380V, 3-Phase drives.

EN61000-3-2

- 0.75 kW (1 HP) 240V 1-Phase and 3-Phase drives and

0.4 kW (0.5 HP) 240V 1-Phase drives are suitable for installation on a private low voltage power network.

Installations on a public low voltage power network may require additional external harmonic mitigation.

- Other drive ratings meet the current harmonic requirements of EN61000-3-2 without additional external mitigation.

Chapter2 Start Up

This chapter describes how to start up the HPVFE Drive. To simplify drive setup, the most commonly programmed parameters are organized in a single Basic Program Group.

Important:Read the *General Precautions* section before proceeding.



ATTENTION: Power must be applied to the drive to perform the following start-up procedures. Some of the voltages present are at incoming line potential. To avoid electric shock hazard or damage to equipment, only qualified service personnel should perform the following procedure. Thoroughly read and understand the procedure before beginning. If an event does not occur

While performing this procedure, **Do Not Proceed. Remove All Power** including user supplied control voltages. User supplied voltages may exist even when main AC power is not applied to the drive. Correct the malfunction before continuing.

Prepare For Drive Start-Up

Before Applying Power to the Drive

- 1. Confirm that all inputs are connected to the correct terminals and are secure.
- 2. Verify that AC line power at the disconnect device is within the rated value of the drive.
- 3. Verify that any digital control power is 24 volts.
- 4. Verify that the Sink (SNK)/Source (SRC) Setup DIP Switch is set to match your control wiring scheme. See [Figure 1.5 on page 1-14](#) for location.

Important:The default control scheme is Source (SRC). The Stop terminal is jumpered (I/O Terminals 01 and 11) to allow starting from the keypad. If the control scheme is changed to Sink (SNK), the jumper must be removed from I/O Terminals 01 and 11 and installed between I/O Terminals 01 and 04.

- 5. Verify that the Stop input is present or the drive will not start.

Important:If I/O Terminal 01 is used as a stop input, the jumper between I/O Terminals 01 and 11 must be removed.

Applying Power to the Drive

- 6. Apply AC power and control voltages to the drive.
- 7. Familiarize yourself with the integral keypad features (see [page 2-3](#)) before setting any Program Group parameters.

Start, Stop, Direction and Speed Control

Factory default parameter values allow the drive to be controlled from the integral keypad. No programming is required to start, stop, change direction and control speed directly from the integral keypad.

Important: To disable reverse operation, see [A434](#) [Reverse Disable].

If a fault appears on power up, refer to [Fault Descriptions on page 4-3](#) for an explanation of the fault code.

Variable Torque Fan/Pump Applications





For improved motor tuning performance when using a premium efficient motor on a variable torque load, set [A453](#) [Boost Select] to option 2 “35.0, VT”.





Integral Keypad

Menu	Description
P	Display Group(View Only) Consists of commonly viewed drive operating conditions.
d	Basic Program Group Consists of commonly used programmable function.
t	Terminal Block Group Consists of programmable functions for control terminals.
C	Communications Group Consists of programmable functions for communications.
A	Advanced Program Group Consists of remaining programmable functions.
F	Fault Designator Consists of list of codes for specific fault conditions. Displayed only when fault is present.



No.	LED	LED State	Description
①	Run/Direction Status	Steady Red	Indicates drive is running and commanded motor direction.
		Flashing Red	Drive has been commanded to change direction. Indicates actual motor direction while decelerating to zero.
②	Alphanumeric Display	Steady Red	Indicates parameter number, parameter value, or fault code.
		Flashing Red	Single digit flashing indicates that digit can be edited. All digits flashing indicates a fault condition.
③	Displayed Units	Steady Red	Indicates the units of the parameter value being displayed.
④	Program Status	Steady Red	Indicates parameter value can be changed.
⑤	Fault Status	Flashing Red	Indicates drive is faulted.
⑥	Pot Status	Steady Green	Indicates potentiometer on Integral Keypad is active.
⑦	Start Key Status	Steady Green	Indicates Start key on Integral Keypad is active. The Reverse key is also active unless disabled by A434 [Reverse Disable].















No.	Key	Name	Description
⑧		Escape	Back one step in programming menu. Cancel a change to a parameter value and exit Program Mode.
		Select	Advance one step in programming menu. Select a digit when viewing parameter value.
		Up Arrow	Scroll through groups and parameters.
		Down Arrow	Increase/decrease the value of a flashing digit.
		Enter	Advance one step in programming menu. Save a change to a parameter value.



















No.	LED	LED State	Description
9		Speed Potentiometer	Used to control speed of drive. Default is active. Controlled by parameter P108 [Speed Reference].
		Start	Used to start the drive. Default is active. Controlled by parameter P106 [Start Source].
		Reverse	Used to reverse direction of the drive. Default is active. Controlled by parameters P106 [Start Source] and A434 [Reverse Disable].
		Stop	Used to stop the drive or clear a fault. This key is always active. Controlled by parameter P107 [Stop Mode].

Viewing and Editing Parameters

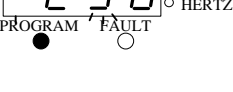
The last user-selected Display Group parameter is saved when power is removed and is displayed by default when power is reapplied.

The following is an example of basic integral keypad and display functions. This example provides basic navigation instructions and illustrates how to program the first Program Group parameter.

Step	Key(s)	Example Displays
1. When power is applied, the last user-selected Display Group parameter number is briefly displayed with flashing characters. The display then defaults to that parameter's current value. (Example shows the value of d001 [Output Freq] with the drive stopped.)		
2. Press Esc once to display the Display Group parameter number shown on power-up. The parameter number will flash.		
3. Press Esc again to enter the group menu. The group menu letter will flash.		
4. Press the Up Arrow or Down Arrow to scroll through the group menu (d, P, t, C and A).	 或 	
Press Enter or Sel to enter a group. The rightmost digit of the last viewed parameter in that group will flash.	 或 	
5. Press the Up Arrow or Down Arrow to scroll through the parameters in the group.	 或 	

Step	Key(s)	Example Displays
6. Press Enter or Sel to view the value of a parameter. If you do not want to edit the value, press Esc to return to the parameter number.	 或 	
7. Press Enter or Sel to enter program mode to edit the parameter value. The rightmost digit will flash and the Program LED will illuminate if the parameter can be edited.	 或 	
8. Press the Up Arrow or Down Arrow to change the parameter value.	 或 	
If desired, press Sel to move from digit to digit or bit to bit. The digit or bit that you can change will flash.		
9. Press Esc to cancel a change. The digit will stop flashing, the previous value is restored and the Program LED will turn off.		
Or Press Enter to save a change. The digit will stop flashing and the Program LED will turn off.		
10. Press Esc to return to the parameter list. Continue to press Esc to back out of the programming menu.		
		

The Basic Program Group ([page 3-8](#)) contains the most commonly changed parameters.

Chapter 3 Programming and Parameters

Chapter 3 provides a complete listing and description of the HPVFE parameters. Parameters are programmed (viewed/edited) using the integral keypad. Refer to [Appendix B](#) for catalog numbers.

For information on...	See page...
About Parameters	3-1
Parameter Organization	3-2
Display Group	3-3
Basic Program Group	3-8
Terminal Block Group	3-13
Communications Group	3-17
Advanced Program Group	3-19
Parameter Cross Reference – by Name	3-31

About Parameters

To configure a drive to operate in a specific way, drive parameters may have to be set. Three types of parameters exist:

ENUM

ENUM parameters allow a selection from 2 or more items. Each item is represented by a number.

Numeric Parameters

These parameters have a single numerical value (i.e. 0.1 Volts).

Bit Parameters





Bit parameters have four individual bits associated with features or conditions. If the bit is 0, the feature is off or the condition is false. If the bit is 1, the feature is on or the condition is true.

Some parameters are marked as follows.

 = Stop drive before changing this parameter.

 = 32 bit parameter. Parameters marked 32 bit will have two parameter numbers when using RS485 communications and programming software.

Parameter Organization

Group	Parameters	
Basic Display 	Output Freqd001 Commanded Freqd002 Output Currentd003 Output Voltaged004 DC Bus Voltaged005 Drive Statusd006 Fault 1 Coded007 Fault 2 Coded008 Fault 3 Coded009 Process Displayd010	Control Sourced012 Contrl In Statusd013 Dig In Statusd014 Comm Statusd015 Control SW Verld016 Drive Typed017 Elapsed Run Timed018 Testpoint Datad019 Analog In 0-10Vd020 Analog In 4-20mAd021 Drive Tempd022
Basic Program 	Motor NP VoltsP101 Motor NP HertzP102 Motor OL CurrentP103 Minimum FreqP104 Maximum FreqP105 Start SourceP106	Stop ModeP107 Speed ReferenceP108 Accel Time 1P109 Decel Time 1P110 Motor OL RetP111 Reset To DefaultsP112
Terminal Block 	Digital In1 Selt201 Digital In2 Selt202 Analog In 0-10V Lot211 Analog In 0-10V Hit212	Analog In 4-20mA Lo d213 Analog In 4-20mA Hi d214 Relay Out Selt221 Relay Out Levelt222
Communications 	LanguageC301 Comm Data RateC302 Comm Node AddrC303 Comm Loss ActionC304 Comm Loss TimeC305 Comm FormatC306 Comm Write ModeC307	
Advanced Program 	Accel Time 2A401 Decel Time 2A402 S Curve %A403 Jog FrequencyA404 Jog Accel/DecelA405 Internal FreqA409 Preset Freq 0A410 Preset Freq 1A411 Preset Freq 2A412 Preset Freq 3A413 Skip FrequencyA418 Skip Freq BandA419 DC Brake TimeA424 DC Brake LevelA425 DB Resistor SelA427 DB Duty CycleA428 Start At PowerUpA433 Reverse DisableA434 Flying Start EnA435	CompensationA436 Slip Hertz @ FLAA437 Process Time LoA438 Process Time HiA439 Process FactorA440 Bus Reg ModeA441 Current LimitA442 Motor OL SelectA444 PWM FrequencyA446 SW Current TripA448 Fault ClearA450 Auto Rstrt TriesA451 Auto Rstrt DelayA452 Boost SelectA453 Maximum VoltageA457 Program LockA458 Testpoint SelA459 Motor NP FLAA461

Display Group

d001 [Output Freq]

Related Parameter(s): [d002](#), [d010](#), [P104](#), [P105](#), [P108](#)

Output frequency present at T1, T2 & T3 (U, V & W).

Values	Default	Read Only
	Min/Max:	0.0/ P105 [Maximum Freq]
	Display:	0.1 Hz

d002 [Commanded Freq]

Related Parameter(s): [d001](#), [d013](#), [P104](#), [P105](#), [P108](#)

Value of the active frequency command. Displays the commanded frequency even if the drive is not running.

Important: The frequency command can come from a number of sources. Refer to [Start and Speed Reference Control on page 1-19](#) for details.

Values	Default	Read Only
	Min/Max:	0.0/ P105 [Maximum Freq]
	Display:	0.1 Hz

d003 [Output Current]

The output current present at T1, T2 & T3 (U, V & W).

Values	Default	Read Only
	Min/Max:	0.00/(Drive Rated Amps x 2)
	Display:	0.01 Amps

d004 [Output Voltage]

Related Parameter(s): [P101](#), [A453](#), [A457](#)

Output voltage present at terminals T1, T2 & T3 (U, V & W).

Values	Default	Read Only
	Min/Max:	0/Drive Rated Volts
	Display:	0.1 VAC

d005 [DC Bus Voltage]

Present DC bus voltage level.

Values	Default	Read Only
	Min/Max:	Based on Drive Rating
	Display:	1 VDC

Display Group (continued)

d006[Drive Status]

Related Parameter(s): [A434](#)

Present operating condition of the drive.

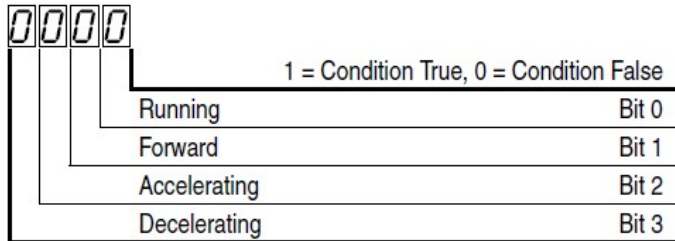

Values	Default	Read Only
	Min/Max:	0/1
	Display:	1

d007 [Fault 1 Code]

d008 [Fault 2 Code]

d009 [Fault 3 Code]

A code that represents a drive fault. The codes will appear in these parameters in the order they occur (d007 [Fault 1 Code] = the most recent fault). Repetitive faults will only be recorded once.

Refer to [Chapter 4](#) for fault code descriptions.

Values	Default	Read Only
	Min/Max:	F2/F122
	Display:	F1

d010 [Process Display]

Related Parameter(s): [d001](#), [A440](#), [A438](#), [A439](#)



32 bit parameter.

The output frequency scaled by [A440](#) [Process Factor] or by [A438](#) [Process Time Lo] and [A439](#) [Process Time Hi].

Output Freq X Process Factor = Process Display

Values	Default	Read Only
	Min/Max:	0.00/9999
	Display:	0.01 – 1

Display Group (continued)

d012[Control Source]

Related Parameter(s): [P106](#), [P108](#), [t201](#), [t202](#)

Displays the active source of the Start Command and Speed Command which are normally defined by the settings of [P106](#) [Start Source] and [P108](#) [Speed Reference] but may be overridden by digital inputs. Refer to the flowcharts on pages [1-19](#) and [1-20](#) for details.

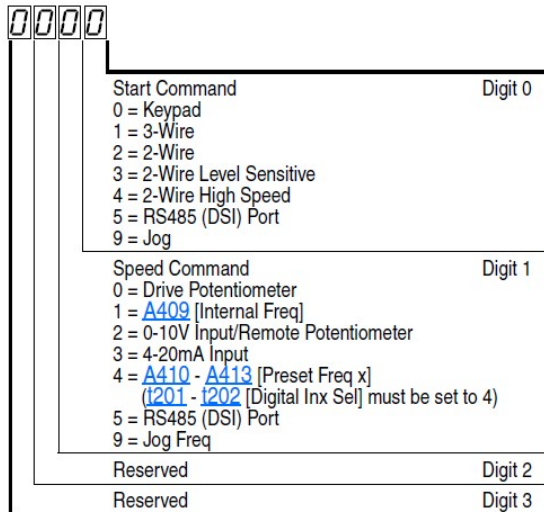

Values	Default	Read Only
Min/Max:		0/9
Display:		1

d013 [Contrl In Status]

Related Parameter(s): [d002](#), [P104](#), [P105](#)

Status of the control terminal block control inputs.

Important: Actual control commands may come from a source other than the control terminal block.

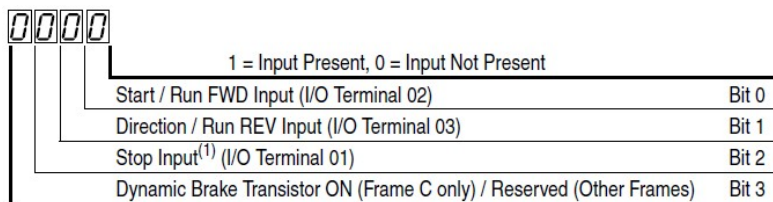

(1)The stop input must be present in order to start the drive.

When this bit is a 1 the drive can be started.

When this bit is a 0 the drive will stop.

Values	Default	Read Only
Min/Max:		0/1
Display:		1

Display Group (continued)

d014 [Dig In Status]

Related Parameter(s): [t201](#), [t202](#)

Status of the control terminal block digital inputs.

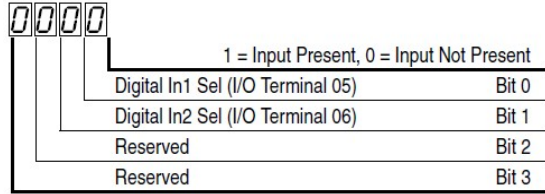

Values	Default	Read Only
Min/Max:		0/1
Display:		1

d015 [Comm Status]

Related Parameter(s): [C302](#) - [C306](#)

Status of the communications ports.

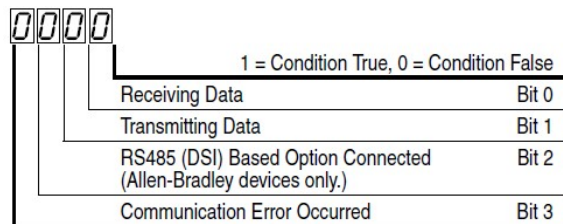

Values	Default	Read Only
Min/Max:		0/1
Display:		1

d016 [Control SW Ver]

Main Control Board software version.

Values	Default	Read Only
Min/Max:		1.00/99.99
Display:		0.01

d017 [Drive Type]

Used by Rockwell Automation field service personnel.

Values	Default	Read Only
Min/Max:		1001/9999
Display:		1

Display Group *(continued)*

d018 [Elapsed Run Time]

Accumulated time drive is outputting power. Time is displayed in 10-hour increments.

Values	Default	Read Only
	Min/Max:	0/9999 Hrs
	Display:	1 (= 10 Hrs)

d019 [Testpoint Data]

Related Parameter(s): [A459](#)

The present value of the function selected in [A459](#) [Testpoint Sel].

Values	Default	Read Only
	Min/Max:	0/FFFF
	Display:	1 Hex

d020 [Analog In 0-10V]

Related Parameter(s): [t211](#), [t212](#)

The present value of the voltage at I/O Terminal 13 (100.0% = 10 volts).

Values	Default	Read Only
	Min/Max:	0.0/100.0%
	Display:	0.1%

d021 [Analog In 4-20mA]

Related Parameter(s): [t213](#), [t214](#)

The present value of the current at I/O Terminal 15 (0.0% = 4mA, 100.0% = 20mA).

Values	Default	Read Only
	Min/Max:	0.0/100.0%
	Display:	0.1%

d022 [Drive Temp]

Present operating temperature of the drive power section.

Values	Default	Read Only
	Min/Max:	0/120 degC
	Display:	1 degC

Basic Program Group

P101 [Motor NP Volts]

Related Parameter(s): [d004](#), [A453](#)

 Stop drive before changing this parameter.

Set to the motor nameplate rated voltage.

Values	Default	Based on Drive Rating
Min/Max:		20/Drive Rated Voltage
Display:		1 VAC

P102 [Motor NP Hertz]

Related Parameter(s): [A453](#), [A444](#)

 Stop drive before changing this parameter.

Set to the motor nameplate rated frequency.

Values	Default	Based on Drive Rating
Min/Max:		10/400 Hz
Display:		1 Hz

P103

[Motor OL Current]

Related Parameter(s): [P111](#), [t221](#), [A441](#), [A444](#), [A448](#), [A437](#)

Set to the maximum allowable motor current.

The drive will fault on an F7 Motor Overload if the value of this parameter is exceeded by 150% for 60 seconds or 200% for 3 seconds.

Values	Default	Based on Drive Rating
Min/Max:		0.0/(Drive Rated Amps · 2)
Display:		0.1 Amps

P104 [Minimum Freq]

Related Parameter(s): [d001](#), [d002](#), [d013](#), [P105](#), [t211](#), [t213](#), [A438](#)

Sets the lowest frequency the drive will output continuously.

Values	Default	Based on Drive Rating
Min/Max:		0.0/400.0 Hz
Display:		0.1 Hz

P105 [Maximum Freq]

Related Parameter(s): [d001](#), [d002](#), [d013](#), [P104](#), [A404](#), [t212](#), [t214](#), [A438](#)

 Stop drive before changing this parameter.

Sets the highest frequency the drive will output.

Values	Default	Based on Drive Rating
Min/Max:		0/400 Hz
Display:		1 Hz

Basic Program Group (continued)

P106 [Start Source]

Related Parameter(s): [d012](#), [P107](#)

 Stop drive before changing this parameter.

Sets the control scheme used to start the drive.

Refer to [Start and Speed Reference Control on page 1-19](#) for details about how other drive settings can override the setting of this parameter.

Important: For all settings except option 3, the drive must receive a leading edge from the start input for the drive to start after a stop input, loss of power or fault condition.

Options	0 “Keypad” (Default)	<input type="checkbox"/> Integral keypad controls drive operation. <input type="checkbox"/> I/O Terminal 1 “Stop” = coast to stop. <input type="checkbox"/> When active, the Reverse key is also active unless disabled by A434 [Reverse Disable].
	1 “3-Wire”	I/O Terminal 1 “Stop” = stop according to the value set in P107 [Stop Mode].
	2 “2-Wire”	I/O Terminal 1 “Stop” = coast to stop.
	3 “2-W Lvl Sens”	Drive will restart after a “Stop” command when: <input type="checkbox"/> Stop is removed and <input type="checkbox"/> Start is held active
<div style="display: flex; align-items: center;">  <p>ATTENTION: Hazard of injury exists due to unintended operation. When P106 [Start Source] is set to option 3, and the Run input is maintained, the Run inputs do not need to be toggled after a Stop input for the drive to run again. A Stop function is provided only when the Stop input is active (open).</p> </div>		
	4 “2-W Hi Speed”	<p>Important: There is greater potential voltage on the output terminals when using this option.</p> <input type="checkbox"/> Outputs are kept in a ready-to-run state. The drive will respond to a “Start” command within 10 ms. <input type="checkbox"/> I/O Terminal 1 “Stop” = coast to stop.
	5 “Comm Port”(1)	<input type="checkbox"/> Remote communications. Refer to Appendix C for details. I/O Terminal 1 “Stop” = coast to stop.

(1)When using option 5 “Comm Port”, if the drive is using a network for control and the user’s program is maintaining a “Start” or “Jog” command without sending a “Stop command”, the drive will start automatically when power is cycled.

Basic Program Group (continued)

P107 [Stop Mode]

Related Parameter(s): [P106](#), [A418](#), [A425](#), [A427](#), [C304](#)

Active stop mode for all stop sources [e.g. keypad, run forward (I/O Terminal 02), run reverse (I/O Terminal 03), RS485 port] except as noted below.

Important: I/O Terminal 01 is always a coast to stop input except when [P106](#) [Start Source] is set for "3-Wire" control. When in three wire control, I/O Terminal 01 is controlled by [P107](#) [Stop Mode].

Options	0 "Ramp, CF"(1) (Default)	Ramp to Stop. "Stop" command clears active fault.
	1 "Coast, CF"(1)	Coast to Stop. "Stop" command clears active fault.
	2 "DC Brake, CF"(1)	DC Injection Braking Stop. "Stop" command clears active fault.
	3 "DCBrkAuto,CF"(1)	DC Injection Braking Stop with Auto Shutoff. <input type="checkbox"/> Standard DC Injection Braking for value set in A424 [DC Brake Time]. OR <input type="checkbox"/> Drive shuts off if the drive detects that the motor is stopped. "Stop" command clears active fault.
	4 "Ramp"	Ramp to Stop.
	5 "Coast"	Coast to Stop.
	6 "DC Brake"	DC Injection Braking Stop.
	7 "DC BrakeAuto"	DC Injection Braking Stop with Auto Shutoff. <input type="checkbox"/> Standard DC Injection Braking for value set in A424 [DC Brake Time]. OR <input type="checkbox"/> Drive shuts off if current limit is exceeded.

(1) Stop input also clears active fault.

Basic Program Group (continued)

P108 [Speed Reference]

Related Parameter(s): [d001](#), [d002](#), [d012](#), [P109](#), [P110](#), [t201](#), [t202](#), [A409](#), [A410-A413](#), [t211](#), [t212](#), [t213](#), [t214](#)

Sets the source of the speed reference to the drive.

The drive speed command can be obtained from a number of different sources. The source is normally determined by [P108](#) [Speed Reference]. However, when [t201](#) - [t202](#) [Digital Inx Sel] is set to option 2, 4, 5, 6, 11, 12, 13, 14 and the digital input is active, the speed reference commanded by [P108](#) [Speed Reference] will be overridden. Refer to the flowchart on [page 1-19](#) for more information on speed reference control priority.

Options	0 "Drive Pot" (Default)	Internal frequency command from the potentiometer on the integral keypad.
	1 "InternalFreq"	Internal frequency command from A409 [Internal Freq].
	2 "0-10V Input"	External frequency command from the 0-10V analog input or remote potentiometer.
	3 "4-20mA Input"	External frequency command from the 4-20mA analog input.
	4 "Preset Freq"	External frequency command as defined by A410 - A413 [Preset Freq x] when t201 and t202 [Digital Inx Sel] are programmed as "Preset Frequencies" and the digital inputs are active.
	5 "Comm Port"	External frequency command from the communications port.

P109 [Accel Time 1]

Related Parameter(s): [P108](#), [P110](#), [t201](#), [t202](#), [A401](#), [A410-A413](#)

Sets the rate of acceleration for all speed increases.

Values	Default	10.0 Secs
	Min/Max:	0.0/600.0 Secs
	Display:	0.1 Secs

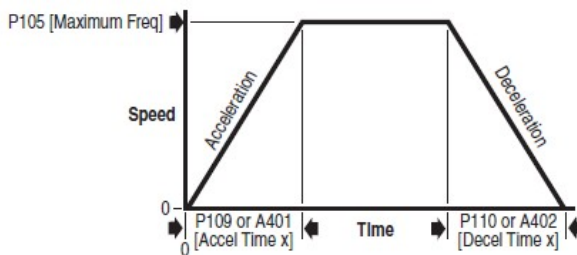

Basic Program Group (continued)

P110 [Decel Time 1]

Related Parameter(s): [P108](#), [P109](#), [t201](#), [t202](#), [A402](#), [A410-A413](#)

Sets the rate of deceleration for all speed decreases.

Maximum Freq/Decel Time =Decel Rate

Values	Default	10.0 Secs
	Min/Max:	0.1/600.0 Secs
	Display:	0.1 Secs

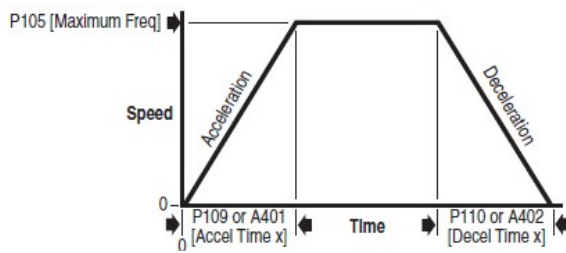

P111 [Motor OL Ret]

Related Parameter(s): [P103](#)

Enables/disables the Motor Overload Retention function. When Enabled, the value held in the motor overload counter is saved at power-down and restored at power-up. A change to this parameter setting resets the counter.

Options	0 "Disabled" (Default)	10.0 Secs
	1 "Enabled"	0.1 Secs

P112 [Reset To Defaults]



Stop drive before changing this parameter.

Resets all parameter values to factory defaults.

Options	0 "Idle State" (Default)	
	1 "Reset Defaults"	<input type="checkbox"/> After the reset function is complete, this parameter will set itself back to "0". <input type="checkbox"/> Causes an F48 Params Defaulted fault.

Terminal Block Group

t201 [Digital In1 Sel]

(I/O Terminal 5)

Related Parameter(s): [d012](#), [d014](#), [P108](#), [P109](#), [P110](#),
[t211-t214](#), [A401](#), [A402](#), [A404](#), [A405](#), [A410-A413](#)

t202 [Digital In2 Sel]

(I/O Terminal 6)



Stop drive before changing this parameter.

Selects the function for the digital inputs. Refer to the flowchart on [page 1-19](#) for more information on speed reference control priority.

Options	0 "Not Used"	Terminal has no function but can be read over network communications via d014 [Dig In Status]
1 "Acc 2 & Dec 2"	<input type="checkbox"/> When active, A401 [Accel Time 2] and A402 [Decel Time 2] are used for all ramp rates except Jog. <input type="checkbox"/> Can only be tied to one input. Refer to the flowchart on page 1-20 for more information on Accel/Decel selection.	
2 "Jog"	<input type="checkbox"/> When input is present, drive accelerates according to the value set in A405 [Jog Accel/Decel] and ramps to the value set in A404 [Jog Frequency]. <input type="checkbox"/> When input is removed, drive ramps to a stop according to the value set in A405 [Jog Accel/Decel]. <input type="checkbox"/> A valid "Start" command will override this input.	
3 "Aux Fault"	When enabled, an F2 Auxiliary Input fault will occur when the input is removed.	
4 "Preset Freq" (Default)	Refer to A410 - A413 [Preset Freq x]. Important: Digital Inputs have priority for frequency control when programmed as a Preset Speed and are active. Refer to the flowchart on 1-19 for more information on speed reference control priority.	
5 "Local"	When active, sets integral keypad as start source and potentiometer on the integral keypad as speed source.	
6 "Comm Port"	<input type="checkbox"/> When active, sets communications device as default start/speed command source. <input type="checkbox"/> Can only be tied to one input.	
7 "Clear Fault"	When active, clears an active fault.	
8 "RampStop,CF"	Causes drive to immediately ramp to a stop regardless of how P107 [Stop Mode] is set.	
9 "CoastStop,CF"	Causes drive to immediately coast to a stop regardless of how P107 [Stop Mode] is set.	
10 "DCInjStop,CF"	Causes drive to immediately begin a DC Injection stop regardless of how P107 [Stop Mode] is set.	
11 "Jog Forward"	Drive accelerates to A404 [Jog Frequency] according to A405 [Jog Accel/Decel] and ramps to stop when input becomes inactive. A valid start will override this command.	
12 "Jog Reverse"	Drive accelerates to A404 [Jog Frequency] according to A405 [Jog Accel/Decel] and ramps to stop when input becomes inactive. A valid start will override this command.	

t201 & t202	13 "10V In Ctrl"	Selects 0-10V or ±10V control as the frequency reference. Start source is not changed.
Options (Cont.)	14 "20mA In Ctrl"	Selects 4-20mA control as the frequency reference. Start source is not changed.
	15 "Anlg Invert"	Inverts the scaling of the analog input levels set in t211 [Anlg In 0-10V Lo] and t212 [Anlg In 0-10V Hi] or t213 [Anlg In4-20mA Lo] and t214 [Anlg In4-20mA Hi].
	16-27	Reserved

t211 [Anlg In 0-10V Lo]

Related Parameter(s): [d020](#), [P104](#), [P108](#), [t201](#), [t202](#)

Sets the analog input level that corresponds to [P104](#) [Minimum Freq] if a 0-10V input is used by [P108](#) [Speed Reference].

Analog inversion can be accomplished by setting this value larger than [t212](#) [Anlg In 0-10V Hi] or by setting [t201](#) - [t202](#) [Digital Inx Sel] to option 15 "Anlg Invert".

Values	Default	0.0%
	Min/Max:	0.0/ 100.0%
	Display:	0.1%

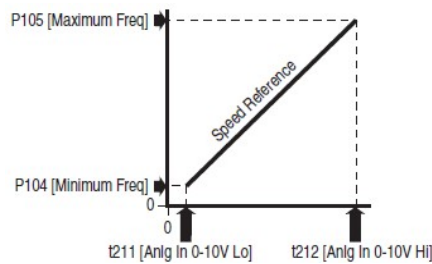

t212 [Anlg In 0-10V Hi]

Related Parameter(s): [d020](#), [P105](#), [P108](#), [t201](#), [t202](#)

Sets the analog input level that corresponds to [P105](#) [Maximum Freq] if a 0-10V input is used by [P108](#) [Speed Reference].

Analog inversion can be accomplished by setting this value smaller than [t211](#) [Anlg In 0-10V Lo] or by setting [t201](#) - [t202](#) [Digital Inx Sel] to option 15 "Anlg Invert".

Values	Default	100.0%
	Min/Max:	0.0/ 100.0%
	Display:	0.1%

t213 [Anlg In4-20mA Lo]

Related Parameter(s): [d021](#), [P104](#), [P108](#), [t201](#), [t202](#)

Sets the analog input level that corresponds to [P104](#) [Minimum Freq] if a 4-20mA input is used by [P108](#) [Speed Reference].

Analog inversion can be accomplished by setting this value larger than [t214](#) [Anlg In4-20mA Hi] or by setting [t201](#) - [t202](#) [Digital Inx Sel] to option 15 "Anlg Invert".

Values	Default	0.0%
	Min/Max:	0.0/ 100.0%
	Display:	0.1%

Terminal Block Group *(continued)*

t214 [Anlg In4-20mA Hi]

 Related Parameter(s): [d021](#), [P105](#), [P108](#), [t201](#), [t202](#)

Sets the analog input level that corresponds to [P105](#) [Maximum Freq] if a 4-20mA input is used by [P108](#) [Speed Reference].

Analog inversion can be accomplished by setting this value smaller than [t213](#) [Anlg In4-20mA Lo] or by setting [t201](#) - [t202](#) [Digital Inx Sel] to option 15 "Anlg Invert".

Values	Default	100.0%
Min/Max:		0.0/ 100.0%
Display:		0.1%

t221 [Relay Out Sel]

 Related Parameter(s): [P103](#), [t222](#), [A451](#)

Sets the condition that changes the state of the output relay contacts.

Options		
0 "Ready/Fault" (Default)		Relay changes state when power is applied. This indicates that the drive is ready for operation. Relay returns drive to shelf state when power is removed or a fault occurs.
1 "At Frequency"		Drive reaches commanded frequency.
2 "MotorRunning"		Motor is receiving power from the drive.
3 "Reverse"		Drive is commanded to run in reverse direction.
4 "Motor Overld"		Motor overload condition exists.
5 "Ramp Reg"		Ramp regulator is modifying the programmed accel/decel times to avoid an overcurrent or overvoltage fault from occurring.
6 "Above Freq"		Drive exceeds the frequency (Hz) value set in t222 [Relay Out Level].
7 "Above Cur"		Drive exceeds the current (% Amps) value set in t222 [Relay Out Level]. Important: Value for t222 [Relay Out Level] must be entered in percent of drive rated output current.
8 "Above DCVolt"		Drive exceeds the DC bus voltage value set in t222 [Relay Out Level].
9 "Retries Exst"		Value set in A451 [Auto Rstrt Tries] is exceeded.
10 "Above Anlg V"		<input type="checkbox"/> Analog input voltage (I/O Terminal 13) exceeds the value set in t222 [Relay Out Level]. <input type="checkbox"/> This parameter setting can also be used to indicate a PTC trip point when the input (I/O Terminal 13) is wired to a PTC and external resistor. <input type="checkbox"/> Use t222 to set threshold.
11 "ParamControl"		Enables the output to be controlled over network communications by writing to t222 [Relay Out Level]. (0 = Off, 1 = On.)
12 "NonRec Fault"		<input type="checkbox"/> Value set in A451 [Auto Rstrt Tries] is exceeded. <input type="checkbox"/> A451 [Auto Rstrt Tries] is not enabled. <input type="checkbox"/> A Non-resettable fault has occurred.
13 "I/O Control"		Enables the output to be controlled by bit 6 of the logic command word. See Writing (06) Logic Command Data on page C-4 for more information.
14-22		Reserved

Terminal Block Group *(continued)*

t222 [Relay Out Level]

Related Parameter(s): [t221](#)



32 bit parameter.

Sets the trip point for the digital output relay if the value of [t221](#) [Relay Out Sel] is 6, 7, 8, 10 or 11.

t221 Setting	t222 Min/Max
	0/400 Hz
6	0/180%
7	0/815 Volts
8	0/100%
10	0/1
11	

Values	Default	0.0
	Min/Max:	As above
	Display:	0.1%

Communications Group

C301 [Language]

Selects the language displayed by the remote communications option.

Options	1"English" (Default)
	2"Second Lang" (Reserved)

C302 [Comm Data Rate]

Related Parameter(s): [d015](#)

Sets the serial port rate for the RS485 (DSI) port.

Important: Power to drive must be cycled before any changes will affect drive operation.

Options	0"1200"
	1"2400"
	2"4800"
	3"9600" (Default)
	4"19.2K"
	5"38.4K"

C303 [Comm Node Addr]

Related Parameter(s): [d015](#)

Sets the drive node address for the RS485 (DSI) port if using a network connection.

Important: Power to drive must be cycled before any changes will affect drive operation.

Values	Default	100
	Min/Max:	1/247
	Display:	1

C304 [Comm Loss Action]

Related Parameter(s): [d015](#), [P107](#), [C305](#)

Selects the drive's response to a loss of the communication connection or excessive communication errors.

Options	0"Fault" (Default)	Drive will fault on an F81 Comm Loss and coast to stop.
	1"Coast to Stop"	Stops drive via coast to stop.
	2"Stop"	Stops drive via P107 [Stop Mode] setting.
	3"Continu Last"	Drive continues operating at communication commanded speed saved in RAM.

Communications Group *(continued)*

C305 [Comm Loss Time]

Related Parameter(s): [d015](#), [C304](#)

Sets the time that the drive will remain in communication loss before implementing the option selected in [C304](#) [Comm Loss Action].

Values	Default	5.0 Secs
	Min/Max:	0.1/ 60.0 Secs
	Display:	0.1 Secs

C306 [Comm Format]

Selects the protocol (RTU only), data bits (8 data bits only), parity (None, Even, Odd), and stop bits (1 stop bit only) used by the RS485 port on the drive.

Refer to [Appendix C](#) for details on using the drive communication features.

Important: Power to drive must be cycled before any changes will affect drive operation.

Options	0"RTU 8-N-1" (Default)
	1"RTU 8-E-1"
	2"RTU 8-O-1"
	3"RTU 8-N-2"
	4"RTU 8-E-2"
	5"RTU 8-O-2"

C307 [Comm Write Mode]

Determines whether parameter changes made over communication port are saved and stored in Non-Volatile Storage (NVS) or RAM only. If they are stored in RAM, the values will be lost at power-down.

Options	0"Save" (Default)
	1"RAM Only"



ATTENTION: Risk of equipment damage exists. If a controller is programmed to write parameter data to Non-Volatile Storage (NVS) frequently, the NVS will quickly exceed its life cycle and cause the drive to malfunction. Do not create a program that frequently uses configurable outputs to write parameter data to NVS unless C307 [Comm Write Mode] is set to option 1.

Advanced Program Group

A401 [Accel Time 2]

Related Parameter(s): [P109](#)

When active, sets the rate of acceleration for all speed increases except jog. Refer to the flowchart on [page 1-20](#) for details.

Maximum Freq / Accel Time=Accel Rate

Values	Default	20.0 Secs
	Min/Max:	0.1/ 600.0 Secs
	Display:	0.1 Secs

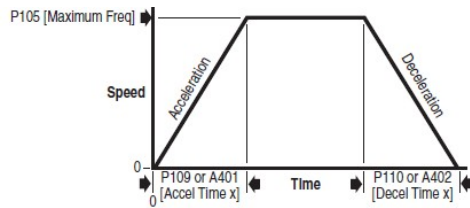

A402 [Decel Time 2]

Related Parameter(s): [P110](#)

When active, sets the rate of deceleration for all speed decreases except jog. Refer to the flowchart on [page 1-20](#) for details.

Maximum Freq / Decel Time=Decel Rate

Values	Default	20.0 Secs
	Min/Max:	0.1/ 600.0 Secs
	Display:	0.1 Secs

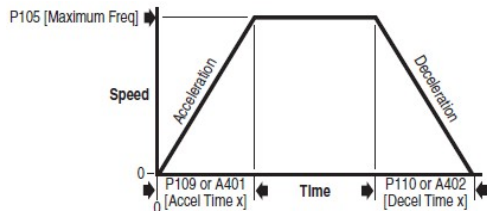

Advanced Program Group *(continued)*

A403 [S Curve %]

Sets the percentage of acceleration or deceleration time that is applied to the ramp as S Curve. Time is added, 1/2 at the beginning and 1/2 at the end of the ramp.

Values	Default	0% (Disabled)
	Min/Max:	0/100%
	Display:	1%

Example:

Accel Time = 10 Seconds
 S Curve Setting = 50%
 S Curve Time = $10 \times 0.5 = 5$ Seconds
 Total Time = $10 + 5 = 15$ Seconds

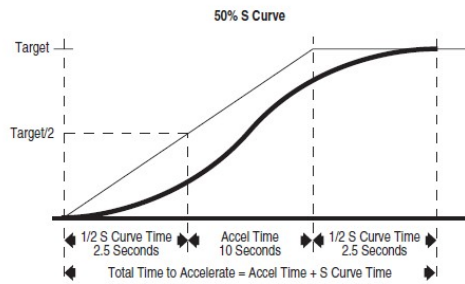

A404 [Jog Frequency]

Related Parameter(s): [P105](#), [t201](#), [t202](#), [A405](#)

Sets the output frequency when a jog command is issued.

Values	Default	10.0 Hz
	Min/Max:	0.0/ P105 [Maximum Freq]
	Display:	0.1 Hz

A405

[Jog Accel/Decel]

Related Parameter(s): [t201](#), [t202](#), [A404](#)

Sets the acceleration and deceleration time when a jog command is issued.

Values	Default	10.0 Secs
	Min/Max:	0.1/600.0 Secs
	Display:	0.1 Secs

A409 [Internal Freq]

Related Parameter(s): [P108](#)

Provides the frequency command to the drive when [P108](#) [Speed Reference] is set to 1 "Internal Freq". When enabled, this parameter will change the frequency command in "real time" using the integral keypad Up Arrow or Down Arrow when in program mode.

Important: Once the desired command frequency is reached, the Enter key must be pressed to store this value to EEPROM memory. If the ESC key is used before the Enter key, the frequency will return to the original value following the normal accel/decel curve.

Values	Default	60.0 Hz
	Min/Max:	0.0/400.0 Hz
	Display:	0.1 Hz

Advanced Program Group *(continued)*

A410 [Preset Freq 0]⁽¹⁾

Related Parameter(s): [P108](#), [P109](#), [P110](#), [t201](#), [t202](#), [A401](#), [A402](#)

A411 [Preset Freq 1]

A412 [Preset Freq 2]

A413 [Preset Freq 3]

Values	A410 Default	0.0 Hz
	A411 Default	5.0 Hz
	A412 Default	10.0 Hz
	A413 Default	20.0 Hz
	Min/Max:	0.0/400.0 Hz
	Display:	0.1 Hz

Provides a fixed frequency command value when [t201](#) - [t202](#) [Digital Inx Sel] is set to 4 "Preset Frequencies".

An active preset input will override speed command as shown in the flowchart on [page 1-20](#).

(1)To activate [A410](#) [Preset Freq 0] set [P108](#) [Speed Reference] to option 4 "Preset Freq 0-3"

Input State of Digital In 1(I/O Terminal 05)	Input State of Digital In 2(I/O Terminal 06)	Frequency Source	Accel / Decel Parameter Used ⁽²⁾
0	0	A410 [Preset Freq 0]	[Accel Time 1] / [Decel Time 1]
1	0	A411 [Preset Freq 1]	[Accel Time 1] / [Decel Time 1]
0	1	A412 [Preset Freq 2]	[Accel Time 2] / [Decel Time 2]
1	1	A413 [Preset Freq 3]	[Accel Time 2] / [Decel Time 2]

(2)When a Digital Input is set to "Accel 2 & Decel 2", and the input is active, that input overrides the settings in this table.

A418 [Skip Frequency]

Related Parameter(s): [A419](#)

Sets the frequency at which the drive will not operate.

A setting of 0 disables this parameter.

Values	Default	0Hz
	Min/Max:	0/400 Hz
	Display:	1 Hz

Advanced Program Group *(continued)*

A419 [Skip Freq Band]

Related Parameter(s): [A418](#)

Determines the bandwidth around [A418](#) [Skip Frequency]. A419 [Skip Freq Band] is applied above and below the actual skip frequency. See the diagram below.

A setting of 0.0 disables this parameter.

Values	Default	0.0Hz
	Min/Max:	0.0/30.0 Hz
	Display:	0.1 Hz

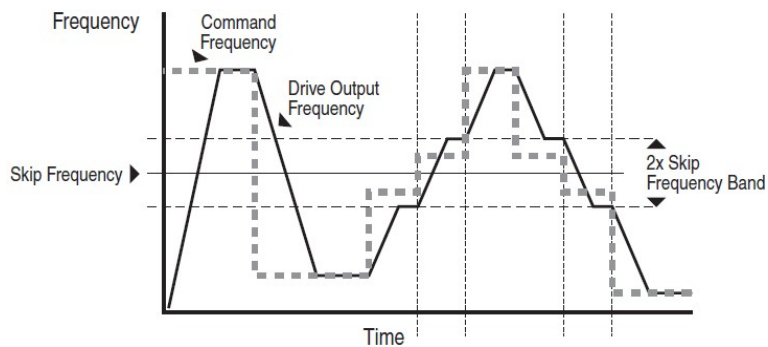

A424 [DC Brake Time]

Related Parameter(s): [P107](#), [A425](#)

Sets the length of time that DC brake current is "injected" into the motor. Refer to parameter [A425](#) [DC Brake Level].

Values	Default	0.0 Secs
	Min/Max:	0.0/99.9 Secs (A setting of 99.9 = Continuous)
	Display:	0.1 Secs

Advanced Program Group (continued)

A425 [DC Brake Level]

Related Parameter(s): [P107](#), [A418](#)

Defines the maximum DC brake current, in amps, applied to the motor when [P107](#) [Stop Mode] is set to either "Ramp" or "DC Brake".

Values	Default	Drive Rated Amps · 0.05
	Min/Max:	0.0/(Drive Rated Amps · 1.8)
	Display:	0.1 Amps

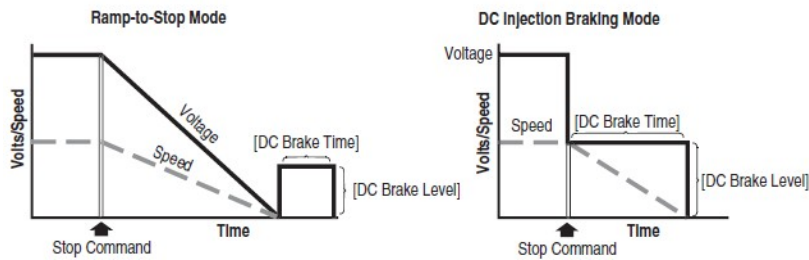

ATTENTION: If a hazard of injury due to movement of equipment or material exists, an auxiliary mechanical braking device must be used.



ATTENTION: This feature should not be used with synchronous or permanent magnet motors. Motors may be demagnetized during braking.

A427 [DB Resistor Sel]

Related Parameter(s): [A428](#)



Stop drive before changing this parameter.

Enables/disables external dynamic braking. This parameter applies only to Frame C drives.

Setting	Min/Max
0	"Disabled"
1	"Normal RA Res" (5% Duty Cycle) - Refer to Table B.C on page B-2
2	"No Protection" (100% Duty Cycle)
3	"% Duty Cycle" Limited (1% – 99% of Duty Cycle) - see A428

The drive is able to provide full braking indefinitely. Braking power is limited by the external DB resistor. When this parameter is set to 1 "Normal RA Res" and an appropriate RA resistor is used (see selection [Table B.C](#)), the drive provides calculated resistor overload protection. However, the drive cannot protect against a brake IGBT failure.



ATTENTION: A risk of fire exists if external braking resistors are not protected. The external resistor package must be self-protected from over temperature or the protective circuit shown in [Figure B.3](#) on page B-7, or equivalent, must be supplied.

Values	Default	0
	Min/Max:	0/3
	Display:	1

Advanced Program Group *(continued)*

A428 [DB Duty Cycle]

Related Parameter(s): [A427](#)

 Stop drive before changing this parameter.

Selects the duty cycle allowed for an external dynamic braking resistor when [A427](#) [DB Resistor Sel] is set to 3. This parameter applies only to Frame C drives.

Values	Default	5%
	Min/Max:	1/99%
	Display:	1%

A433 [Start At PowerUp]

 Stop drive before changing this parameter.

Enables/disables a feature that allows a Start or Run command to automatically cause the drive to resume running at commanded speed after drive input power is restored. Requires a digital input configured for Run or Start and a valid start contact.



ATTENTION: Equipment damage and/or personal injury may result if this parameter is used in an inappropriate application. Do not use this function without considering applicable local, national and international codes, standards, regulations or industry guidelines.

Options	0“Disabled” (Default)
	1“Enabled”

A434 [Reverse Disable]

Related Parameter(s): [d006](#)

 Stop drive before changing this parameter.

Enables/disables the function that allows the direction of motor rotation to be changed. The reverse command may come from a digital command, the keypad or a serial command. All reverse inputs including two-wire Run Reverse will be ignored with reverse disabled.

Options	0“Rev Enabled” (Default)
	1“Rev Disabled”

A435 [Flying Start En]

Sets the condition that allows the drive to reconnect to a spinning motor at actual RPM.

Options	0“Disabled” (Default)
	1“Enabled”

Advanced Program Group *(continued)*

A436 [Compensation]

Enables/disables correction options that may improve problems with motor instability.

Options	0"Disabled"	
	1"Electrical" (Default)	Some drive/motor combinations have inherent instabilities which are exhibited as non-sinusoidal motor currents. This setting attempts to correct this condition.
	2"Mechanical"	Some motor/load combinations have mechanical resonances which can be excited by the drive current regulator. This setting slows down the current regulator response and attempts to correct this condition.
	3"Both"	

A437 [Slip Hertz @ FLA]

Related Parameter(s): [P103](#)

Compensates for the inherent slip in an induction motor. This frequency is added to the commanded output frequency based on motor current.

Values	Default	2.0 Hz
	Min/Max:	0.0/ 10.0 Hz
	Display:	0.1 Hz

A438 [Process Time Lo]

Related Parameter(s): [d010](#), [P104](#)

Scales the time value when the drive is running at [P104](#) [Minimum Freq]. When set to a value other than zero, [d010](#) [Process Display] indicates the duration of the process.

Values	Default	0.00
	Min/Max:	0.00/ 99.99
	Display:	0.01

A439 [Process Time Hi]

Related Parameter(s): [d010](#), [P105](#)

Scales the time value when the drive is running at [P105](#) [Maximum Freq]. When set to a value other than zero, [d010](#) [Process Display] indicates the duration of the process.

Values	Default	0.00
	Min/Max:	0.00/ 99.99
	Display:	0.01

Advanced Program Group *(continued)*

A440 [Process Factor]

Related Parameter(s): [d010](#)

Scales the value displayed by [d010](#) [Process Display].

Output Freq x Process Factor = Process Display

Values	Default	30.0
	Min/Max:	0.1/999.9
	Display:	0.1

A441 [Bus Reg Mode]

Controls the operation of the drive voltage regulation, which is normally operational at deceleration or when the bus voltage rises.

Refer to the Attention statement on page [P-3](#) for important information on bus regulation.

Values	0“Disabled”
	1“Enabled” (Default)

A442 [Current Limit]

Maximum output current allowed before current limiting occurs.

Values	Default	Drive Rated Amps x 1.5
	Min/Max:	0.1/(Drive Rated Amps x 1.8)
	Display:	0.1 Amps

A444 [Motor OL Select]

Related Parameter(s): [P102](#), [P103](#)

Drive provides Class 10 motor overload protection. Settings 0-2 select the derating factor for the I_{2t} overload function.

Options	0“No Derate” (Default)
	1“Min Derate”
	2“Max Derate”

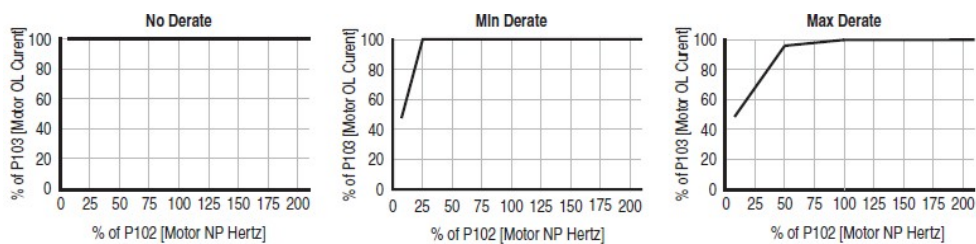

Advanced Program Group *(continued)*

A446 [PWM Frequency]

Sets the carrier frequency for the PWM output waveform. The chart below provides derating guidelines based on the PWM frequency setting.

Important: Ignoring derating guidelines can cause reduced drive performance.

Values	Default	4.0 kHz
	Min/Max:	2.0/10.0 kHz
	Display:	0.1 kHz

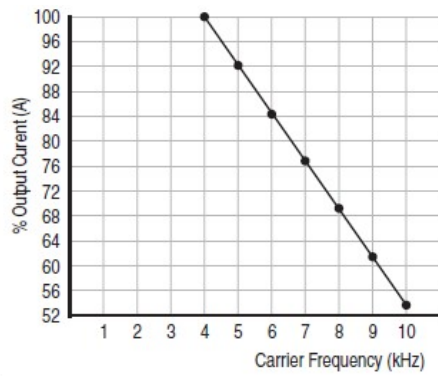

A448 [SW Current Trip]

Related Parameter(s): [P103](#)

Enables/disables a software instantaneous (within 100 ms) current trip.

Values	Default	0.0 (Disabled)
	Min/Max:	0.0/(Drive Rated Amps · 2)
	Display:	0.1 Amps

Advanced Program Group *(continued)*

A450 [Fault Clear]

 Stop drive before changing this parameter.

Resets a fault and clears the fault queue. Used primarily to clear a fault over network communications.

Options	0"Ready/Idle" (Default)
	1"Reset Fault"
	2"Clear Buffer" (Parameters d007-d009 [Fault x Code])

A451 [Auto Rstrt Tries]

Sets the maximum number of times the drive attempts to reset a fault and restart.

Clear a Type 1 fault and restart the drive.

- 1.Set [A451](#) [Auto Rstrt Tries] to a value other than "0".
- 2.Set [A452](#) [Auto Rstrt Delay] to a value other than "0".

Clear an OverVoltage, UnderVoltage or Heatsink OvrTmp fault without restarting the drive.

- 1.Set [A451](#) [Auto Rstrt Tries] to a value other than "0".
- 2.Set [A452](#) [Auto Rstrt Delay] to "0".



ATTENTION: Equipment damage and/or personal injury may result if this parameter is used in an inappropriate application. Do not use this function without considering applicable local, national and international codes, standards, regulations or industry guidelines.

Values	Default	0
	Min/Max:	0/9
	Display:	1

A452 [Auto Rstrt Delay]

Related Parameter(s): [A451](#)

Sets the time between restart attempts when [A451](#) [Auto Rstrt Tries] is set to a value other than zero.

Values	Default	1.0 Secs
	Min/Max:	0.0/120.0 Secs
	Display:	0.1 Secs

Advanced Program Group *(continued)*

A453 [Boost Select]

Related Parameter(s): [d004](#), [P101](#), [P102](#)

Sets the boost voltage (% of P101 [Motor NP Volts]) and redefines the Volts per Hz curve.(1)

(1) Drive may add additional voltage unless option 5 is selected.

Options	1 "30.0, VT"	Variable Torque
	2 "35.0, VT"	
	3 "40.0, VT"	
	4 "45.0, VT"	
	5 "0.0 no IR"	Constant Torque
	6 "0.0"	
	7 "2.5, CT"	
	[Default for 3.7, 5.5, 7.5 & 11.0 kW (5.0, 7.5, 10.0 & 15.0 HP) Drives]	
	8 "5.0, CT" (Default)	
	9 "7.5, CT"	
	10 "10.0, CT"	
	11 "12.5, CT"	
	12 "15.0, CT"	
	13 "17.5, CT"	
	14 "20.0, CT"	

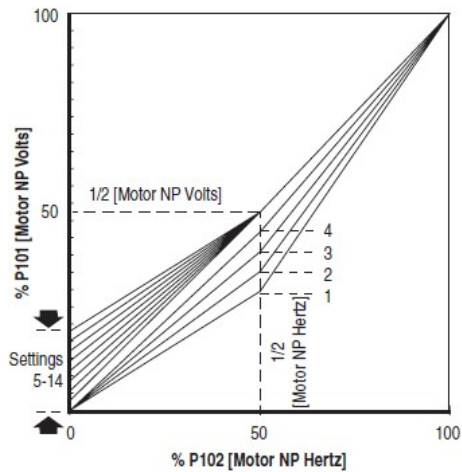

Advanced Program Group *(continued)*

A457 [Maximum Voltage]

Sets the highest voltage the drive will output.

Values	Default	Drive Rated Volts
	Min/Max:	20/Drive Rated Volts
	Display:	1 VAC

A458 [Program Lock]

Protects parameters against change by unauthorized personnel.

Options	0"Unlocked" (Default)
	1"Locked"

A459 [Testpoint Sel]

Used by Solcom&Hapn (shanghai) electric field service personnel.

Values	Default	400
	Min/Max:	0/FFFF
	Display:	1 Hex

A461 [Motor NP FLA]

Set to the motor nameplate rated full load amps.

Values	Default	Drive Rated Amps
	Min/Max:	0.1/(Drive Rated Amps x 2)
	Display:	0.1 Amps

Parameter Cross Reference – by Name

Parameter Name	Number	Group	Page
Accel Time 1	P109	Basic Program	3-11
Accel Time 2	A401	Advanced Program	3-19
Analog In 0-10V	d020	Display	3-7
Analog In 4-20mA	d021	Display	3-7
Anlg In 0-10V Hi	t212	Terminal Block	3-14
Anlg In 0-10V Lo	t211	Terminal Block	3-14
Anlg In4-20mA Hi	t214	Terminal Block	3-15
Anlg In4-20mA Lo	t213	Terminal Block	3-14
Auto Rstrt Delay	A452	Advanced Program	3-28
Auto Rstrt Tries	A451	Advanced Program	3-28
Boost Select	A453	Advanced Program	3-29
Bus Reg Mode	A441	Advanced Program	3-26
Comm Data Rate	C302	Communications	3-17
Comm Format	C306	Communications	3-18
Comm Loss Action	C304	Communications	3-17
Comm Loss Time	C305	Communications	3-18
Comm Node Addr	C303	Communications	3-17
Comm Status	d015	Display	3-6
Comm Write Mode	C307	Communications	3-18
Commanded Freq	d002	Display	3-3
Compensation	A436	Advanced Program	3-25
Contrl In Status	d013	Display	3-5
Control Source	d012	Display	3-5
Control SW Ver	d016	Display	3-6
Current Limit	A441	Advanced Program	3-26
DB Duty Cycle	A428	Advanced Program	3-24
DB Resistor Sel	A427	Advanced Program	3-23
DC Brake Level	A425	Advanced Program	3-23
DC Brake Time	A424	Advanced Program	3-21
DC Bus Voltage	d005	Display	3-3
Decel Time 1	P110	Basic Program	3-12
Decel Time 2	A402	Advanced Program	3-19
Dig In Status	d014	Display	3-6
Digital In1 Sel	t201	Terminal Block	3-13
Digital In2 Sel	t202	Terminal Block	3-13
Drive Status	d006	Display	3-4
Drive Temp	d022	Display	3-7
Drive Type	d017	Display	3-6
Elapsed Run Time	d018	Display	3-7
Fault 1 Code	d007	Display	3-4
Fault 2 Code	d008	Display	3-4
Fault 3 Code	d009	Display	3-4
Fault Clear	A450	Advanced Program	3-28
Flying Start En	A435	Advanced Program	3-24
Internal Freq	A409	Advanced Program	3-20
Jog Accel/Decel	A405	Advanced Program	3-20
Jog Frequency	A404	Advanced Program	3-20
Language	C301	Communications	3-17
Maximum Freq	P105	Basic Program	3-8
Maximum Voltage	A457	Advanced Program	3-30
Minimum Freq	P104	Basic Program	3-8
Motor NP FLA	A461	Advanced Program	3-30
Motor NP Hertz	P102	Basic Program	3-8
Motor NP Volts	P101	Basic Program	3-8
Motor OL Current	P103	Basic Program	3-8
Motor OL Ret	P111	Basic Program	3-12
Motor OL Select	A444	Advanced Program	3-26
Output Current	d003	Display	3-3
Output Freq	d001	Display	3-3
Output Voltage	d004	Display	3-3
Preset Freq 0	A410	Advanced Program	3-21
Preset Freq 1	A411	Advanced Program	3-21
Preset Freq 2	A412	Advanced Program	3-21
Preset Freq 3	A413	Advanced Program	3-21
Process Display	d010	Display	3-4
Process Factor	A440	Advanced Program	3-26
Process Time Hi	A439	Advanced Program	3-25
Process Time Lo	A438	Advanced Program	3-25
Program Lock	A458	Advanced Program	3-30
PWM Frequency	A446	Advanced Program	3-27
Relay Out Level	t222	Terminal Block	3-16
Relay Out Sel	t221	Terminal Block	3-15
Reset To Defaults	P112	Basic Program	3-12
Reverse Disable	A434	Advanced Program	3-24
S Curve %	A403	Advanced Program	3-20
Skip Freq Band	A419	Advanced Program	3-22
Skip Frequency	A418	Advanced Program	3-21
Slip Hertz @ FLA	A437	Advanced Program	3-25
Speed Reference	P108	Basic Program	3-11
Start At PowerUp	A433	Advanced Program	3-24
Start Source	P106	Basic Program	3-9
Stop Mode	P107	Basic Program	3-10
SW Current Trip	A448	Advanced Program	3-27
Testpoint Data	d019	Display	3-7
Testpoint Sel	A459	Advanced Program	3-30

Chapter 4 Troubleshooting

Chapter 4 provides information to guide you in troubleshooting the HPVFE drive. Included is a listing and description of drive faults (with possible solutions, when applicable).

For information on...	See page...	For information on...	See page...
Drive Status	4-1	Fault Descriptions	4-3
Faults	4-1	Common Symptoms and Corrective Actions	4-5

Drive Status

The condition or state of your drive is constantly monitored. Any changes will be indicated through the integral keypad.

LED Indications

See [page 2-3](#) for information on drive status indicators and controls.

Faults

A fault is a condition that stops the drive. There are two fault types.



Type	Fault Description	
①	Auto-Reset/Run	When this type of fault occurs, and A451 [Auto Rstrt Tries] is set to a value greater than “0,” a user-configurable timer, A452 [Auto Rstrt Delay], begins. When the timer reaches zero, the drive attempts to automatically reset the fault. If the condition that caused the fault is no longer present, the fault will be reset and the drive will be restarted.
②	Non-Resetable	This type of fault may require drive or motor repair, or is caused by wiring or programing errors. The cause of the fault must be corrected before the fault can be cleared.

Fault Indication

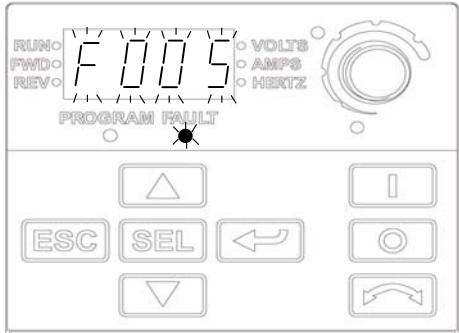
Manually Clearing Faults

Condition	Display
<p>Drive is indicating a fault.</p> <p>The integral keypad provides visual notification of a fault condition by displaying the following.</p> <ul style="list-style-type: none"> <input type="checkbox"/> Flashing fault number <input type="checkbox"/> Flashing fault indicator <p>Press the Escape key to regain control of the integral keypad.</p>	 <p>The diagram shows a control panel with a digital display showing 'F005' and 'PROGRAM FAULT' with a flashing indicator. To the left of the display are indicators for RUN, FWD, and REV. To the right are indicators for VOLTS, AMPS, and HERTZ. Below the display is a keypad with buttons for ESC, SEL, left arrow, right arrow, up arrow, and down arrow.</p>

Manually Clearing Faults

Step	Key(s)
<p>1. Press Esc to acknowledge the fault. The fault information will be removed so that you can use the integral keypad.</p> <p>Access d007 Fault 1 Code to view the most recent fault information.</p> <p>2. Address the condition that caused the fault.</p> <p>The cause must be corrected before the fault can be cleared.</p> <p>See Table 4.A.</p> <p>3. After corrective action has been taken, clear the fault by one of these methods.</p> <ul style="list-style-type: none"> <input type="checkbox"/> Press Stop if P107 [Stop Mode] is set to a value between "0" and "3". <input type="checkbox"/> Cycle drive power. <input type="checkbox"/> Set A450 [Fault Clear] to "1" or "2". <input type="checkbox"/> Cycle digital input if t201 - t202 [Digital Inx Select] is set to option 7 "Clear Fault". 	<p></p> <p></p>

Automatically Clearing Faults

Option / Step

Clear a Type 1 fault and restart the drive.

1. Set **A451** [Auto Rstrt Tries] to a value other than "0".
2. Set **A452** [Auto Rstrt Delay] to a value other than "0".

Clear an OverVoltage, UnderVoltage or Heatsink OvrTmp fault without restarting the drive.

1. Set **A451** [Auto Rstrt Tries] to a value other than "0".
2. Set **A452** [Auto Rstrt Delay] to "0".

Auto Restart (Reset/Run)

The Auto Restart feature provides the ability for the drive to automatically perform a fault reset followed by a start attempt without user or application intervention. This allows remote or "unattended" operation. Only certain faults are allowed to be reset. Certain faults (Type 2) that indicate possible drive component malfunction are not resettable.

Caution should be used when enabling this feature, since the drive will attempt to issue its own start command based on user selected programming.

Fault Descriptions

Table 4.A Fault Types, Descriptions and Actions

No.	Fault	Type(1)	Description	Action
F2	Auxiliary Input	①	Auxiliary input interlock is open.	1.Check remote wiring. 2.Verify communications programming for intentional fault.
F3	Power Loss	②	Excessive DC Bus voltage ripple.	1.Monitor the incoming line for phase loss or line imbalance. 2.Check input line fuse.
F4	UnderVoltage	①	DC bus voltage fell below the minimum value.	Monitor the incoming AC line for low voltage or line power interruption.
F5	OverVoltage	①	DC bus voltage exceeded maximum value.	Monitor the AC line for high line voltage or transient conditions. Bus overvoltage can also be caused by motor regeneration. Extend the decel time or install dynamic brake option.
F6	Motor Stalled	①	Drive is unable to accelerate motor.	Increase P109 and/or A402 [Accel Time x] or reduce load so drive output current does not exceed the current set by parameter A441 [Current Limit].
F7	Motor Overload	①	Internal electronic overload trip.	1.An excessive motor load exists. Reduce load so drive output current does not exceed the current set by parameter P103 [Motor OL Current]. 2.Verify A453 [Boost Select] setting
F8	Heatsink OvrTmp	①	Heatsink temperature exceeds a predefined value.	1.Check for blocked or dirty heat sink fins. Verify that ambient temperature has not exceeded 40°C (104°F) for IP 30/NEMA 1/UL Type 1 installations or 50°C (122°F) for IP20/Open type installations. 2.Check fan.
F12	HW OverCurrent	②	The drive output current has exceeded the hardware current limit.	Check programming. Check for excess load, improper A453 [Boost Select] setting, DC brake volts set too high or other causes of excess current.
F13	Ground Fault	②	A current path to earth ground has been detected at one or more of the drive output terminals.	Check the motor and external wiring to the drive output terminals for a grounded condition. (1) See page 4-1 for a description of fault types.

(1) See page 4-1 for a description of fault types.

No.	Fault	Type(1)	Description	Action
F33	Auto Rstrt Tries	②	Drive unsuccessfully attempted to reset a fault and resume running for the programmed number of A451 [Auto Rstrt Tries].	Correct the cause of the fault and manually clear.
F38	Phase U to Gnd	②	A phase to ground fault has been detected between the drive and motor in this phase.	1.Check the wiring between the drive and motor.
F39	Phase V to Gnd			2.Check motor for grounded phase.
F40	Phase W to Gnd			3.Replace drive if fault cannot be cleared.
F41	Phase UV Short	②	Excessive current has been detected between these two output terminals.	1.Check the motor and drive output terminal wiring for a shorted condition.
F42	Phase UW Short			2.Replace drive if fault cannot be cleared.
F43	Phase VW Short			
F48	Params Defaulted		The drive was commanded to write default values to EEPROM.	1.Clear the fault or cycle power to the drive. 2.Program the drive parameters as needed.
F63	SW OverCurrent	①	Programmed A448 [SW Current Trip] has been exceeded.	Check load requirements and A448 [SW Current Trip] setting.
F64	Drive Overload	②	Drive rating of 150% for 1 minute or 200% for 3 seconds has been exceeded.	Reduce load or extend Accel Time.
F70	Power Unit	②	Failure has been detected in the drive power section.	1.Cycle power. 2.Replace drive if fault cannot be cleared.
F71	Net Loss		The communication network has faulted.	1.Cycle power. 2.Check communications cabling. 3.Check network adapter setting. 4.Check external network status.
F81	Comm Loss	②	RS485 (DSI) port stopped communicating.	1.If adapter was not intentionally disconnected, check wiring to the port. Replace wiring, port expander, adapters or complete drive as required. 2.Check connection. 3.An adapter was intentionally disconnected. 4.Turn off using C304 [Comm Loss Action].
F100	Parameter Checksum	②	The checksum read from the board does not match the checksum calculated.	Set P112 [Reset To Defaults] to option 1 "Reset Defaults".
F122	I/O Board Fail	②	Failure has been detected in the drive control and I/O section.	1.Cycle power. 2.Replace drive if fault cannot be cleared.

(1) See [page 4-1](#) for a description of fault types.

Common Symptoms and Corrective Actions

Motor does not Start.

Cause(s)	Indication	Corrective Action
No output voltage to the motor.	None	Check the power circuit. <input type="checkbox"/> Check the supply voltage. <input type="checkbox"/> Check all fuses and disconnects. Check the motor. <input type="checkbox"/> Verify that the motor is connected properly. Check the control input signals. <input type="checkbox"/> Verify that a Start signal is present. If 2-Wire control is used, verify that either the Run Forward or Run Reverse signal is active, but not both. <input type="checkbox"/> Verify that I/O Terminal 01 is active. <input type="checkbox"/> Verify that P106 [Start Source] matches your configuration. <input type="checkbox"/> Verify that A434 [Reverse Disable] is not prohibiting movement.
Improper boost setting at initial start-up.	None	Set A453 [Boost Select] to option 2 "35.0, VT".
Drive is Faulted	Flashing red status light	Clear fault. <input type="checkbox"/> Press Stop <input type="checkbox"/> Cycle power <input type="checkbox"/> Set A450 [Fault Clear] to option 1 "Clear Faults". <input type="checkbox"/> Cycle digital input if t201 - t202 [Digital Inx Sel] is set to option 7 "Clear Fault".

Drive does not Start from Integral Keypad.

Cause(s)	Indication	Corrective Action
Integral keypad is not enabled.	Green LED above Start key is not illuminated.	<input type="checkbox"/> Set parameter P106 [Start Source] to option 0 "Keypad". <input type="checkbox"/> Set parameter t201 - t202 [Digital Inx Select] to option 5 "Local" and activate the input.
I/O Terminal 01 "Stop" input is not present.	None	Wire inputs correctly and/or install jumper.

Drive does not Start from Start or Run Inputs wired to the terminal block.

Cause(s)	Indication	Corrective Action
Drive is Faulted	Flashing red status light	Clear fault. <input type="checkbox"/> Press Stop • Cycle power <input type="checkbox"/> Set A450 [Fault Clear] to option 1 “Clear Faults”. <input type="checkbox"/> Cycle digital input if t201 - t202 [Digital Inx Select] is set to option 7 “Clear Fault”.
Incorrect programming. <input type="checkbox"/> P106 [Start Source] is set to option 0 “Keypad” or option 5 “RS485 (DSI) Port”. <input type="checkbox"/> t201 - t202 [Digital Inx Select] is set to option 5 “Local” and the input is active.	None	Check parameter settings.
Incorrect input wiring. See 1-15 for wiring examples. <input type="checkbox"/> 2 wire control requires Run Forward, Run Reverse or Jog input. <input type="checkbox"/> 3 wire control requires Start and Stop inputs <input type="checkbox"/> Stop input is always required.	None	Wire inputs correctly and/or install jumper.
Incorrect Sink/Source DIP switch setting.	None	Set switch to match wiring scheme.

Drive does not respond to changes in speed command.

Cause(s)	Indication	Corrective Action
No value is coming from the source of the command.	The drive “Run” indicator is lit and output is 0 Hz.	<input type="checkbox"/> Check d012 [Control Source] for correct source. <input type="checkbox"/> If the source is an analog input, check wiring and use a meter to check for presence of signal. <input type="checkbox"/> Check d002 [Commanded Freq] to verify correct command.
Incorrect reference source is being selected via remote device or digital inputs.	None	<input type="checkbox"/> Check d012 [Control Source] for correct source. <input type="checkbox"/> Check d014 [Dig In Status] to see if inputs are selecting an alternate source. Verify settings for t201 - t202 [Digital Inx Select]. <input type="checkbox"/> Check P108 [Speed Reference] for the source of the speed reference. Reprogram as necessary. <input type="checkbox"/> Review the Speed Reference Control chart on page 1-19 .

Motor and/or drive will not accelerate to commanded speed.

Cause(s)	Indication	Corrective Action
Acceleration time is excessive.	None	Reprogram P109 [Accel Time 1] or A401 [Accel Time 2].
Excess load or short acceleration times force the drive into current limit, slowing or stopping acceleration.	None	Compare d003 [Output Current] with A441 [Current Limit]. Remove excess load or reprogram P109 [Accel Time 1] or A401 [Accel Time 2]. Check for improper A453 [Boost Select] setting.
Speed command source or value is not as expected.	None	Verify d002 [Commanded Freq]. Check d012 [Control Source] for the proper Speed Command.
Programming is preventing the drive output from exceeding limiting values.	None	Check P105 [Maximum Freq] to insure that speed is not limited by programming.

Motor operation is unstable.

Cause(s)	Indication	Corrective Action
Motor data was incorrectly entered.	None	1. Correctly enter motor nameplate data into P101 , P102 and P103 . 2. Enable A436 [Compensation]. 3. Use A453 [Boost Select] to reduce boost level.

Drive will not reverse motor direction.

Cause(s)	Indication	Corrective Action
Digital input is not selected for reversing control.	None	Check [Digital Inx Sel] (See page 3-13). Choose correct input and program for reversing mode.
Digital input is incorrectly wired.	None	Check input wiring. (See page 1-14)
Motor wiring is improperly phased for reverse.	None	Switch two motor leads.
Reverse is disabled.	None	Check A434 [Reverse Disable].

Drive does not power up.

Cause(s)	Indication	Corrective Action
No input power to drive.	None	Check the power circuit. <input type="checkbox"/> Check the supply voltage. <input type="checkbox"/> Check all fuses and disconnects.
Jumper between I/O Terminals P2 and P1 not installed and/or DC Bus Inductor not connected.	None	Install jumper or connect DC Bus Inductor.

Appendix A Supplemental Drive Information

For information on...	See page...
Drive, Fuse & Circuit Breaker Ratings	A-1
Specifications	A-2

Drive, Fuse & Circuit Breaker Ratings

The tables on the following pages provide drive ratings and recommended AC line input fuse and circuit breaker information. Both types of short circuit protection are acceptable for UL and IEC requirements. Sizes listed are the recommended sizes based on 40 degree C and the U.S. N.E.C. Other country, state or local codes may require different ratings.

Fusing

If fuses are chosen as the desired protection method, refer to the recommended types listed below. If available amp ratings do not match the tables provided, the next lower fuse rating that exceeds the drive input rating should be chosen.

- IEC – BS88 (British Standard) Parts 1 & 2 (1), EN60269-1, Parts 1 & 2, type gG or equivalent should be used.
- UL – UL Class RK1, T or J must be used. (2)

Circuit Breakers

Refer to listings in the following tables for recommended circuit breakers (inverse time or instantaneous trip) and 140M Self-Protecting Motor Starters.

(1) Typical designations include, but may not be limited to the following; Parts 1 & 2: AC, AD, BC, BD, CD, DD, ED, EFS, EF, FF, FG, GF, GG, GH.

(2) Typical designations include :Type J - JKS, LPJ, DFJ

Type T - JJS, JJN

Type RK1 - LPS, KTS, KTN

Specifications

Drive Ratings				Catalog Number	Frame	Size W×H×D
Input Voltage	kW	HP	Output Current(A)			
240V 50/60Hz 1- phase	0.2	0.25	1.6	HPVFE02S0D2	A	72 × 185.5 × 143.5
	0.4	0.5	2.5	HPVFE02S0D4		
	0.75	1	4.2	HPVFE02S0D75		
	1.5	2	8	HPVFE02S1D5	B	100 × 174 × 145
	2.2	3	11	HPVFE02S2D2		
240V 50/60Hz 1- phase ,with filter ⁽¹⁾	0.2	0.25	1.6	HPVFE02S0D201	A	72 × 185.5 × 143.5
	0.4	0.5	2.5	HPVFE02S0D401		
	0.75	1	4.2	HPVFE02S0D7501		
	1.5	2	8	HPVFE02S1D501		
240V 50/60Hz 3- phase	2.2	3	11	HPVFE02S2D201	B	100 × 174 × 145
	0.2	0.25	1.6	HPVFE02T0D2		
	0.4	0.5	2.5	HPVFE02T0D4		
	0.75	1	4.2	HPVFE02T0D75		
	1.5	2	8	HPVFE02T1D5		
	2.2	3	12	HPVFE02T2D2		
	3.7	5	17.5	HPVFE02T3D7		
	5.5	7.5	25	HPVFE02T5D5	C	130 × 253 × 287
	7.5	10	33	HPVFE02T7D5		
480V 50/60Hz 3- phase	0.4	0.5	1.5	HPVFE04T0D4	A	72 × 185.5 × 143.5
	0.75	1	2.5	HPVFE04T0D75		
	1.5	2	4.2	HPVFE04T1D5		
	2.2	3	6	HPVFE04T2D2		
	3.7	5	8.7	HPVFE04T3D7		
	5.5	7.5	13	HPVFE04T5D5		
	7.5	10	18	HPVFE04T7D5		
	11	15	24	HPVFE04T11		
480V 50/60Hz 3- phase with filter ⁽¹⁾	0.4	0.5	1.5	HPVFE04T0D401	A	72 × 185.5 × 143.5
	0.75	1.0	2.5	HPVFE04T0D7501		
	1.5	2.0	4.2	HPVFE04T1D501		
	2.2	3.0	6.0	HPVFE04T2D201		
	3.7	5.0	8.7	HPVFE04T3D701		
	5.5	7.5	13.0	HPVFE04T5D501		
	7.5	10.0	18.0	HPVFE04T7D501		
	11.0	15.0	24.0	HPVFE04T1101		

Note: 5.5kW and above, an internal brake IGBT is supplied.

Input/Output Ratings

Output Frequency: 0-400 Hz (Programmable)

Efficiency: 97.5% (Typical)

Digital Control Inputs (Input Current = 6mA)		Analog Control Inputs
SRC (Source) Mode:	SNK (Sink) Mode:	4-20mA Analog: 250 ohm input impedance
18-24V = ON	0-6V = ON	0-10V DC Analog: 100k ohm input impedance
0-6V = OFF	18-24V = OFF	External Pot: 1-10k ohms, 2 Watt minimum

Control Output (Programmable Output, form C relay)

Resistive Rating: 3.0A at 30V DC, 125V AC and 240V AC Inductive Rating: 0.5A at 30V DC, 125V AC, and 240V AC

Recommended Fuses and Circuit Breakers

Fuse: UL Class J, RK1, T or Type BS88; 600V (550V) or equivalent. Circuit Breakers: HMCP or Bulletin 140M or equivalent.

Protective Features

Motor Protection: I²t overload protection - 150% for 60 Secs, 200% for 3 Secs (Provides Class 10 protection)

Overcurrent: 200% hardware limit, 300% instantaneous fault

Over Voltage: 100-120V AC Input – Trip occurs at 405V DC bus voltage (equivalent to 150V AC incoming line)

200-240V AC Input – Trip occurs at 405V DC bus voltage (equivalent to 290V AC incoming line)

380-460V AC Input – Trip occurs at 810V DC bus voltage (equivalent to 575V AC incoming line)

Under Voltage: 100-120V AC Input – Trip occurs at 210V DC bus voltage (equivalent to 75V AC incoming line)

200-240V AC Input – Trip occurs at 210V DC bus voltage (equivalent to 150V AC incoming line)

380-480V AC Input – Trip occurs at 390V DC bus voltage (equivalent to 275V AC incoming line)

Control Ride Through: Minimum ride through is 0.5 Secs - typical value 2 Secs

Faultless Power Ride Through: 100 milliseconds

Dynamic Braking

Internal brake IGBT included with power ratings 5.5 kW (7.5 HP) and 7.5 kW (10.0 HP) for 240V, 3-phase drives and 5.5 kW (7.5 HP), 7.5 kW (10.0 HP) and 11.0 kW (15.0 HP) for 480V, 3-phase drives. See [Appendix B](#) for ordering information.

Category	Specification	
Environment	Altitude:	1000 m (3300 ft) max. without derating
	Maximum Surrounding Air Temperature without derating:	
	IP20:	-10 to 50° C (14 to 122° F)
	IP20 zero stacking:	-10 to 40° C (14 to 104° F)
	Cooling Method	
	Convection:	120V, 1-Phase, 0.75 kW (1 HP) and below 240V, 1-Phase, 0.4 kW (0.5 HP) and below 240V, 3-Phase, 0.75 kW (1 HP) and below 480V, 3-Phase, 0.75 kW (1 HP) and below All other drive ratings.
	Fan:	
	Storage Temperature:	-40 to 85 degrees C (-40 to 185 degrees F)
	Atmosphere:	Important: Drive must not be installed in an area where the ambient atmosphere contains volatile or corrosive gas, vapors or dust. If the drive is not going to be installed for a period of time, it must be stored in an area where it will not be exposed to a corrosive atmosphere.
Relative Humidity:	0 to 95% non-condensing	
Shock (operating):	15G peak for 11ms duration (±1.0ms)	
Vibration (operating):	1G peak, 5 to 2000 Hz	
Control	Carrier Frequency	2-10 kHz. Drive rating based on 4 kHz.
	Frequency Accuracy	
	Digital Input:	Within ±0.05% of set output frequency.
	Analog Input:	Within 0.5% of maximum output frequency.
	Speed Regulation - Open Loop with Slip Compensation:	±2% of base speed across a 40:1 speed range.
	Stop Modes:	Multiple programmable stop modes including - Ramp, Coast, DC-Brake, Ramp-to-Hold and S Curve.
	Acceleration/Deceleration:	Two independently programmable acceleration and deceleration times. Each time may be programmed from 0 - 600 seconds in 0.1 second increments.
	Intermittent Overload:	150% Overload capability for up to 1 minute 200% Overload capability for up to 3 seconds
Electronic Motor Overload Protection	Class 10 protection with speed sensitive response and power-down overload retention function.	
Electrical	Voltage Tolerance:	200-240V ±10% 380-480V ±10% 460-600V ±10%
	Frequency Tolerance:	48-63 Hz
	Input Phases:	Three-phase input provides full rating. Single-phase operation provides 35% rated current.
	Displacement Power Factor:	0.98 across entire speed range
	Maximum Short Circuit Rating:	100,000 Amps Symmetrical
	Actual Short Circuit Rating:	Determined by AIC Rating of installed fuse/circuit breaker
	Transistor Type:	Isolated Gate Bipolar (IGBT)

HPVFE Estimated Watts Loss (Rated Load, Speed & PWM)

Voltage	kW (HP)	Watts Loss
100-120V, 1-Phase	0.2(0.25)	17
	0.4(0.5)	28
	0.75(1.0)	50
	1.1(1.5)	76
200-240V, 1-Phase	0.2(0.25)	14
	0.4(0.5)	25
	0.75(1.0)	43
	1.5(2.0)	82
	2.2(3.0)	109
200-240V, 3-Phase	0.2(0.25)	16
	0.4(0.5)	26
	0.75(1.0)	44
	1.5(2.0)	84
	2.2(3.0)	115
	3.7(5.0)	159
	5.5(7.5)	239
	7.5(10)	329
380-480V, 3-Phase	0.4(0.5)	24
	0.75(1.0)	41
	1.5(2.0)	74
	2.2(3.0)	92
	3.7(5.0)	135
	5.5(7.5)	190
	7.5(10)	294
	11(15)	378

Appendix B Accessories and Dimensions

For information on...	See page
Product Selection	B-1
Product Dimensions	B-6

Product Selection

Table B.A Catalog Number Description

HP	-	VF	E	04	T	5D5	01
-----		-----	----	---	---	-----	----
Enterprise Code	Type	Series Code	Voltage	Number of Phases	Power Rating	Option	

Table B.B HPVFE Drives

Drive Ratings				Catalog Number	Frame	Size W × H × D
Input Voltage	kW	HP	Output Current(A)	Panel Mount		
240V 50/60Hz 1- phase	0.2	0.25	1.6	HPVFE02S0D2	A	72 × 185.5 × 143.5
	0.4	0.5	2.5	HPVFE02S0D4		
	0.75	1	4.2	HPVFE02S0D75		
	1.5	2	8	HPVFE02S1D5	B	100 × 174 × 145
	2.2	3	11	HPVFE02S2D2		
240V 50/60Hz 1- phase ,with filter ⁽¹⁾	0.2	0.25	1.6	HPVFE02S0D201	A	72 × 185.5 × 143.5
	0.4	0.5	2.5	HPVFE02S0D401		
	0.75	1	4.2	HPVFE02S0D7501		
	1.5	2	8	HPVFE02S1D501	B	100 × 174 × 145
	2.2	3	11	HPVFE02S2D201		
240V 50/60Hz 3- phase	0.2	0.25	1.6	HPVFE02T0D2	A	72 × 185.5 × 143.5
	0.4	0.5	2.5	HPVFE02T0D4		
	0.75	1	4.2	HPVFE02T0D75		
	1.5	2	8	HPVFE02T1D5		
	2.2	3	12	HPVFE02T2D2	B	100 × 174 × 145
	3.7	5	17.5	HPVFE02T3D7		
	5.5	7.5	25	HPVFE02T5D5		
	7.5	10	33	HPVFE02T7D5		
480V 50/60Hz 3- phase	0.4	0.5	1.5	HPVFE04T0D4	A	72 × 185.5 × 143.5
	0.75	1	2.5	HPVFE04T0D75		
	1.5	2	4.2	HPVFE04T1D5		
	2.2	3	6	HPVFE04T2D2		
	3.7	5	8.7	HPVFE04T3D7	B	100 × 174 × 145
	5.5	7.5	13	HPVFE04T5D5		
	7.5	10	18	HPVFE04T7D5		
	11	15	24	HPVFE04T11		
480V 50/60Hz 3- phase with filter ⁽²⁾	0.4	0.5	1.5	HPVFE04T0D401	A	72 × 185.5 × 143.5
	0.75	1.0	2.5	HPVFE04T0D7501		
	1.5	2.0	4.2	HPVFE04T1D501		
	2.2	3.0	6.0	HPVFE04T2D201		
	3.7	5.0	8.7	HPVFE04T3D701	B	100 × 174 × 145
	5.5	7.5	13.0	HPVFE04T5D501		
	7.5	10.0	18.0	HPVFE04T7D501		
	11.0	15.0	24.0	HPVFE04T1101		

⁽¹⁾This filter is suitable for use with a cable length of up to 5 meters (16 feet) for EN55011 class A and 1 meter (3 feet) for EN55011 class B environment.

⁽²⁾This filter is suitable for use with a cable length of up to 10 meters (33 feet) for EN61800-3 Second environment.

Note: 5.5kW and above, an internal brake IGBT is supplied.

Table B.C Dynamic Brake Modules

Input Voltage	KW	HP	Minimum
			Resistance Ω
240V 50/60 Hz 3-Phase	5.5	7.5	18
	7.5	10.0	12
480V 50/60 Hz 3-Phase	5.5	7.5	60
	7.5	10.0	39
	11.0	15.0	36

NOTE:

- (1) The resistors listed in this table are rated for 5% duty cycle.
- (2) Use of Solcom&Hapn resistors is always recommended. The resistors listed have been carefully selected for optimizing performance in a variety of applications. Alternative resistors may be used, however care must be taken when making a selection.
- (3) 11kW Requires two resistors wired in parallel.

Table B.D EMC Line Filters

Drive Ratings			Build-in Filter
240V 50/60 Hz 3- Phase	0.2	0.25	
	0.4	0.5	
	0.75	1	
	1.5	2	
	2.2	3	
480V 50/60 Hz 3- Phase	0.4	0.5	
	0.75	1	
	1.5	2	
	2.2	3	
	3.7	5	
	5.5	7.5	
	7.5	10	
11	15		

Product Dimensions

Table B.I HPVFE Panel Mount Drives – Ratings are in kW and (HP)

Frame	120V AC – 1-Phase	240V AC – 1-Phase	240V AC – 3-Phase	480V AC – 3-Phase
A	0.2 (0.25) 0.4 (0.5)	0.2 (0.25) 0.4 (0.5) 0.75 (1.0)	0.2 (0.25) 0.4 (0.5) 0.75 (1.0) 1.5 (2.0)	0.4 (0.5) 0.75 (1.0) 1.5 (2.0)
B	0.75 (1.0) 1.1 (1.5)	1.5 (2.0) 2.2 (3.0)	2.2 (3.0) 3.7 (5.0)	2.2 (3.0) 3.7 (5.0)
C	-	-	5.5 (7.5) 7.5 (10.0)	5.5 (7.5) 7.5 (10.0) 11.0 (15.0)

Figure B.1 HPVFE Drives Dimensions

– Dimensions are in millimeters and (inches). Weights are in kilograms and (pounds).

A

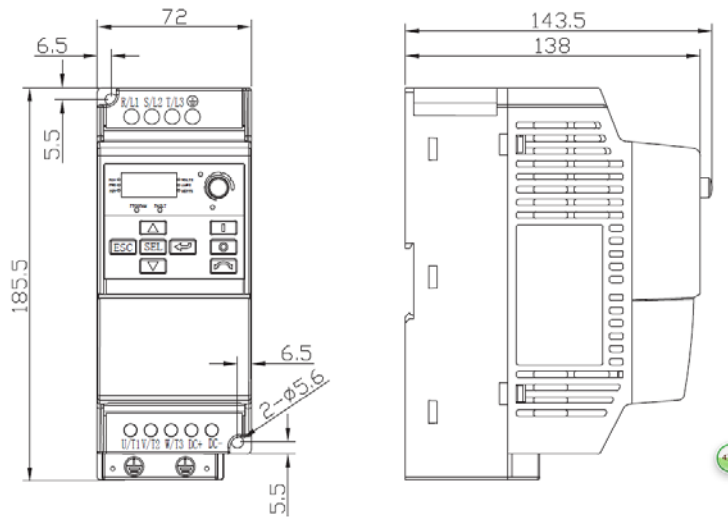

B

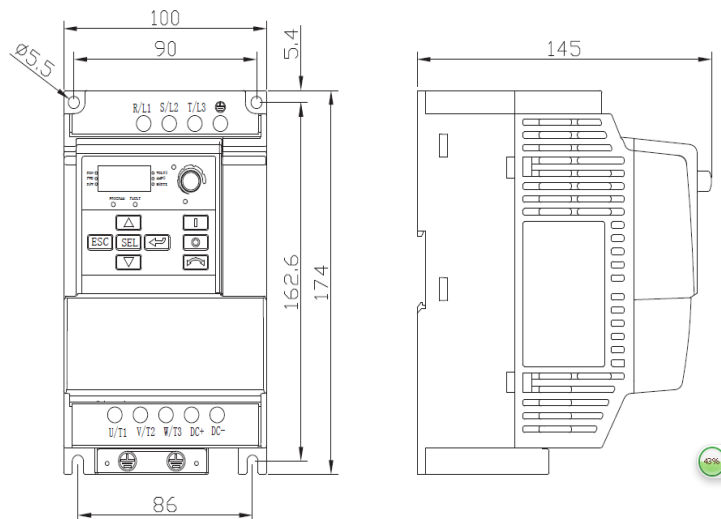

C

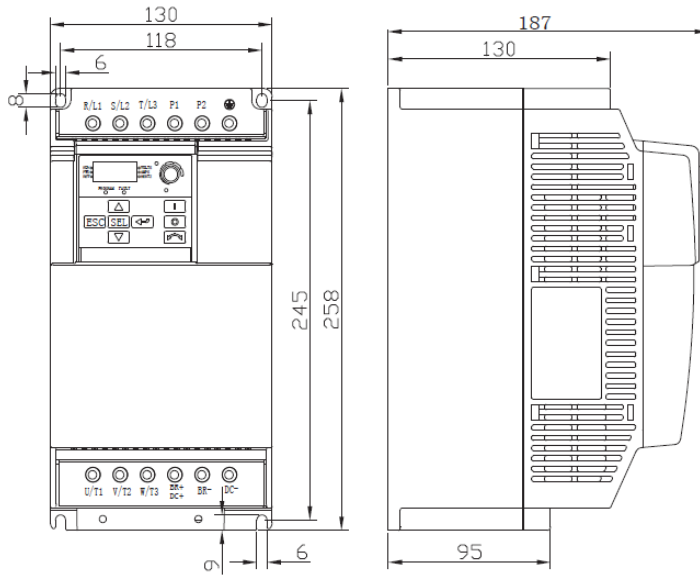

Figure B.2 Dynamic Brake Modules – Dimensions are in millimeters and (inches)

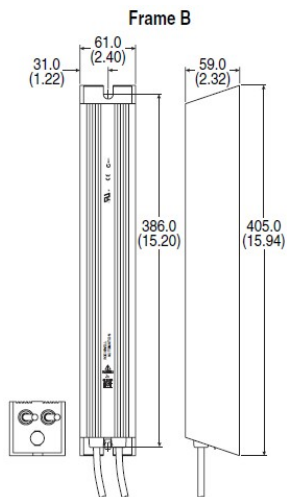
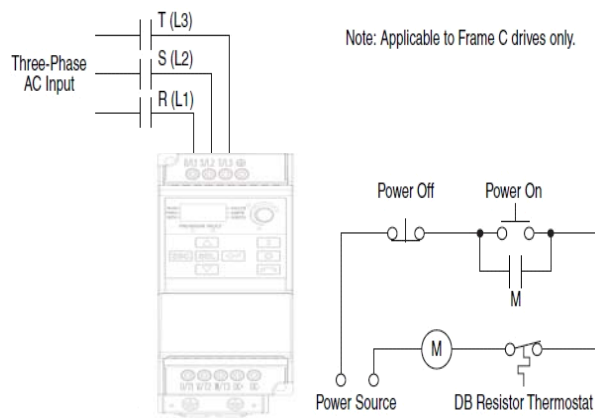

Figure B.3 Recommended External Brake Resistor Circuitry



Appendix C RS485 (DSI) Protocol

HPVFE drives support the RS485 (DSI) protocol to allow efficient operation with Solcom&Hapn peripherals. In addition, some Modbus functions are supported to allow simple networking.

HPVFE drives can be multi-dropped on an RS485 network using Modbus protocol in RTU mode.

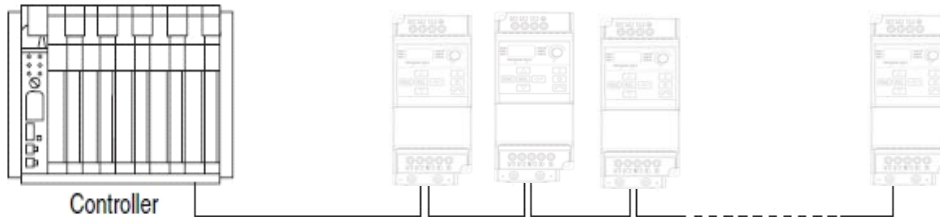

For information regarding DeviceNet or other communication protocols, refer to the appropriate user manual.

Network Wiring

Network wiring consists of a shielded 2-conductor cable that is daisy-chained from node to node.

Figure C.1 Network Wiring Diagram

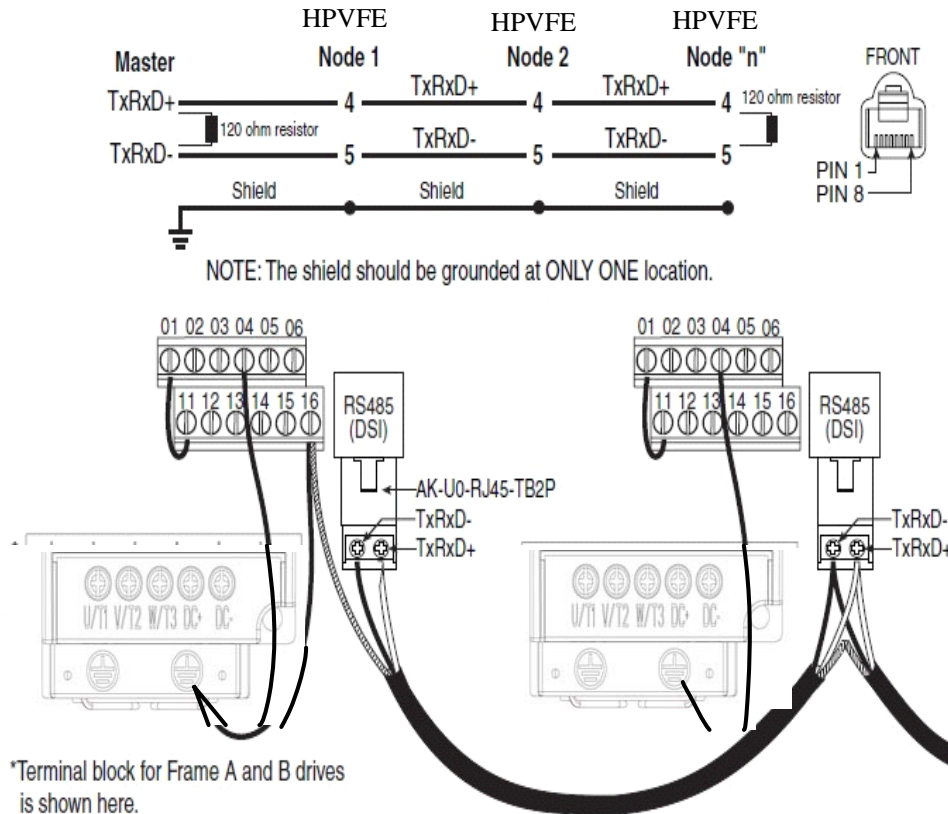

Only pins 4 and 5 on the RJ45 plug should be wired. The other pins on the HPVFE RJ45 socket contain power, etc. for other Solcom&Hapn peripheral devices and must not be connected.

Wiring terminations on the master controller will vary depending on the master controller used and “TxRxD+” and “TxRxD-” are shown for illustration purposes only. Refer to the master controller’s user manual for network terminations. Note that there is no standard for the “+” and “-” wires, and consequently Modbus device manufacturers interpret them differently. If you have problems with initially establishing communications, try

swapping the two network wires at the master controller.

Standard RS485 wiring practices apply.

- Termination resistors need to be applied at each end of the network cable.
- RS485 repeaters may need to be used for long cable runs, or if greater than 32 nodes are needed on the network.
- Network wiring should be separated from power wires by at least 0.3 meters (1 foot).
- Network wiring should only cross power wires at a right angle.

Control Terminal 16 on the HPVFE must also be connected to PE ground (there are two PE terminals on the drive). See [Figure 1.5](#) for more information.

Network Common is internally tied to I/O Terminal 04 (Digital Common). Tying I/O Terminal 04 to PE ground may improve noise immunity in some applications.

Parameter Configuration

The following HPVFE parameters are used to configure the drive to operate on a network.

Parameter	Details	Reference
P106 [Start Source]	Set to 5 “RS485 (DSI) Port” if Start is controlled from the network.	Page 3-9
P108 [Speed Reference]	Set to 5 “RS485 (DSI) Port” if the Speed Reference is controlled from the network.	Page 3-11
C302 [Comm Data Rate]	Sets the data rate for the RS485 (DSI) Port. All nodes on the network must be set to the same data rate.	Page 3-17
C303 [Comm Node Addr]	Sets the node address for the drive on the network. Each device on the network requires a unique node address.	Page 3-17
C304 [Comm Loss Action]	Selects the drive’s response to communication problems.	Page 3-17
C305 [Comm Loss Time]	Sets the time that the drive will remain in communication loss before the drive implements A105 [Comm Loss Action].	Page 3-18
C306 [Comm Format]	Sets the transmission mode, data bits, parity and stop bits for the RS485 (DSI) Port. All nodes on the network must be set to the same setting.	Page 3-18

Supported Modbus Function Codes

The peripheral interface (DSI) used on HPVFE drives supports some of the Modbus function codes.

Modbus Function Code (Decimal)	Command
03	Read Holding Registers
06	Preset (Write) Single Register
16 (10 Hexadecimal)	Preset (Write) Multiple Registers

Important: Modbus devices can be 0-based (registers are numbered starting at 0) or 1-based (registers are numbered starting at 1). Depending on the Modbus Master used, the register addresses listed on the following pages may need to be offset by +1. For example, Logic Command may be register address 8192 for some master devices (e.g. ProSoft 3150-MCM SLC Modbus scanner) and 8193 for others (e.g. PanelViews).

Writing (06) Logic Command Data

The HPVFE drive can be controlled via the network by sending Function Code 06 writes to register address 8192 (Logic Command). P106 [Start Source] must be set to 5 “RS485 (DSI) Port” in order to accept the commands.

In addition to being written, register address 8192 can be read using Function Code 03.

Logic Command		
Address (Decimal)	Bit(s)	Description
8192	0	1 = Stop, 0 = Not Stop
	1	1 = Start, 0 = Not Start
	2	1 = Jog, 0 = No Jog
	3	1 = Clear Faults, 0 = Not Clear Faults
	5,4	00 = No Command 01 = Forward Command 10 = Reverse Command 11 = No Command
	6	Controls the C-form relay when the value of parameter t221 is set to 13. 1 = On, 0 = Off
	7	1 = MOP Increment, 0 = Not Increment
	9,8	00 = No Command 01 = Accel Rate 1 Enable 10 = Accel Rate 2 Enable 11 = Hold Accel Rate Selected
	11,10	00 = No Command 01 = Decel Rate 1 Enable 10 = Decel Rate 2 Enable 11 = Hold Decel Rate Selected
	14,13,12	000 = No Command 001 = Freq. Source = P108 [Speed Reference] 010 = Freq. Source = A409 [Internal Freq] 011 = Freq. Source = Comms (Addr 8193) 100 = A410 [Preset Freq 0] 101 = A411 [Preset Freq 1] 110 = A412 [Preset Freq 2] 111 = A413 [Preset Freq 3]
15	1 = MOP Decrement, 0 = Not Decrement	

Writing (06) Reference

The Speed Reference to a HPVFE drive can be controlled via the network by sending Function Code 06 writes to register address 8193 (Reference). P108 [Speed Reference] must be set to 5 “RS485 (DSI) Port” in order to accept the Speed Reference.

In addition to being written, register address 8193 can be read using Function Code 03.

Reference	
Address (Decimal)	Description
8193	A decimal value entered as xxx.x where the decimal point is fixed. For example, a decimal “100” equals 10.0 Hz and “543” equals 54.3 Hz.

Reading (03) Logic Status Data

The HPVFE Logic Status data can be read via the network by sending Function Code 03 reads to register address 8448 (Logic Status).

Logic Command		
Address (Decimal)	Bit(s)	Description
8448	0	1 = Ready, 0 = Not Ready
	1	1 = Active (Running), 0 = Not Active
	2	1 = Cmd Forward, 0 = Cmd Reverse
	3	1 = Rotating Forward, 0 = Rotating Reverse
	4	1 = Accelerating, 0 = Not Accelerating
	5	1 = Decelerating, 0 = Not Decelerating
	6	1 = Alarm, 0 = No Alarm
	7	1 = Faulted, 0 = Not Faulted
	8	1 = At Reference, 0 = Not At Reference
	9	1 = Reference Controlled by Comm
	10	1 = Operation Cmd Controlled by Comm
	11	1 = Parameters have been locked
	12	Digital Input 1 Status
	13	Digital Input 2 Status
	14	Not Used
15	Not Used	

Reading (03) Feedback

The Feedback (Output Frequency) from the HPVFE drive can be read via the network by sending Function Code 03 reads to register address 8451 (Feedback).

Feedback ⁽¹⁾	
Address (Decimal)	Description
8451	A xxx.x decimal value where the decimal point is fixed. For example, a decimal "123" equals 12.3 Hz and "300" equals 30.0 Hz.

⁽¹⁾Returns the same data as Reading (03) Parameter d001 [Output Freq].

Reading (03) Drive Error Codes

The HPVFE Error Code data can be read via the network by sending Function Code 03 reads to register address 8449 (Drive Error Codes).

Logic Command		
Address (Decimal)	Bit(s)	Description
8449	0	No Fault
	2	Auxiliary Input
	3	Power Loss
	4	Undervoltage
	5	Overvoltage
	6	Motor Stalled
	7	Motor Overload
	8	Heatsink Overtemperature
	12	HW Overcurrent (300%)
	13	Ground Fault
	29	Analog Input Loss
	33	Auto Restart Tries
	38	Phase U to Ground Short
	39	Phase V to Ground Short
	40	Phase W to Ground Short
	41	Phase UV Short
	42	Phase UW Short
	43	Phase VW Short
	63	Software Overcurrent
	64	Drive Overload
	70	Power Unit Fail
80	AutoTune Fail	
81	Communication Loss	
100	Parameter Checksum Error	
122	I/O Board Fail	

Reading (03) and Writing (06) Drive Parameters

To access drive parameters, the Modbus register address equals the parameter number. For example, a decimal “1” is used to address

Parameter **d001** [Output Freq] and decimal “39” is used to address

Parameter **P109** [Accel Time 1].

Additional Information

Refer to <http://www.hapn.com> for additional information.

Appendix D RJ45 DSI Splitter Cable

The HPVFE drive provides a RJ45 port to allow the connection of a single peripheral device. The RJ45 DSI Splitter Cable can be used to connect a second DSI peripheral device to the drive.

Connectivity Guidelines



ATTENTION: Risk of injury or equipment damage exists. The peripherals may not perform as intended if these Connectivity Guidelines are not followed. Precautions should be taken to follow these Connectivity Guidelines.

- Two peripherals maximum can be attached to a drive.
- If a single peripheral is used, it must be connected to the Master port (M) on the splitter and configured for “Auto” (default) or “Master.” Parameter 9 [Device Type] on the DSI keypads and Parameter 1 [Adapter Cfg] on the Serial Converter are used to select the type (Auto / Master / Slave).
- If two peripherals will be powered up at the same time, one must be configured as the “Master” and connected to the Master port (M) and the other must be connected as the “Slave” and connected to the Slave port (S).

DSI Cable Accessories

RJ45 Splitter Cable – Catalog Number: AK-U0-RJ45-SC1

RJ45 Two-Position Terminal Block Adapter –

Catalog Number: AK-U0-RJ45-TB2P

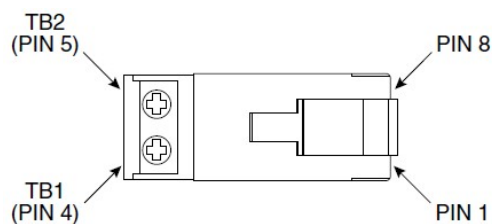

RJ45 Adapter with Integrated Termination Resistor –

Catalog Number: AK-U0-RJ45-TR1

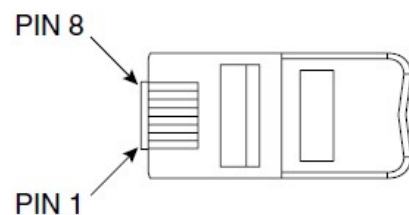

Connecting an RS-485 Network

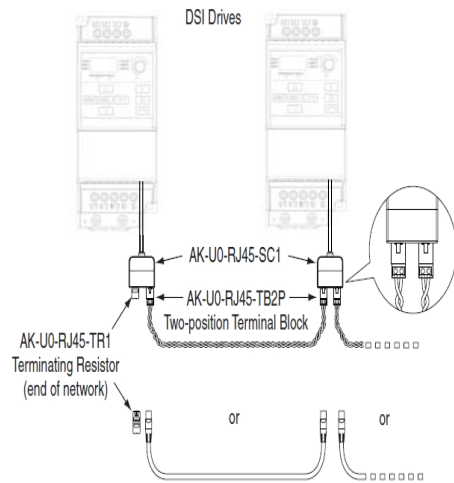

Customer supplied RJ45 male-to-RJ45 male
cables with wires connected at pins 4 and 5 only.

Both the Master (M) and Slave (S) ports on the RJ45 Splitter Cable
operate as standard RS-485 ports in this configuration.

Index

A

AC Supply
Ground, **1-5**
Source, **1-3**
Ungrounded, **1-3**
Advanced Program Group Parameters, **3-19**
Ambient Temperatures, **1-2**
Armored Cable, **1-10**
Auto Rstrt Tries Fault, **4-4**
Auxiliary Input Fault, **4-3**

B

Before Applying Power, **2-1, 2-2**

C

Cable Length, **1-13**
Cable, Power, **1-9**
Catalog Number Explanation, **P-4**
CE Conformity, **1-21**
Checklist, Start-Up, **2-1, 2-2**
Circuit Breakers
Input, **1-7**
Comm Loss Fault, **4-4**
Command Sources for Start and Speed, **1-19**
Communications Group Parameters, **3-17**
Contactors, Input, **1-12**
Control, 2 and 3 Wire, **1-15, 1-18**
Conventions, Manual, **P-2**
Cover, Opening, **1-1**
Cross Reference, Parameter
by Name, **3-31**

D

Dimensions
Drive, **B-6**
Minimum Clearances, **1-2**
Display, **2-3**
Display Group Parameters, **3-3**
Distribution Systems, Ungrounded, **1-3**

Drive Frame Size, **P-2, B-6**
Drive Grounding, **1-5**
Drive Overload Fault, **4-4**
Drive Ratings, **P-4, A-1**
DriveExecutive, **3-1**
DriveExplorer, **3-1**

E

Earthing, see *Grounding*
EMC/RFI
Grounding, Filter, **1-6**
Interference, **1-21**
Enclosure Rating, Changing, **1-2**
ESD, Static Discharge, **P-3**

F

Faults
Auto Rstrt Tries, **4-4**
Auxiliary Input, **4-3**
Comm Loss, **4-4**
Drive Overload, **4-4**
Ground Fault, **4-3**
Heatsink OvrTmp, **4-3**
HW OverCurrent, **4-3**
I/O Board Fail, **4-4**
Motor Overload, **4-3**
Motor Stalled, **4-3**
OverVoltage, **4-3**
Parameter Checksum, **4-4**
Phase Short, **4-4**
Phase to Ground Short, **4-4**
Power Loss, **4-3**
Power Unit, **4-4**
SW OverCurrent, **4-4**
UnderVoltage, **4-3**
Filter, RFI, **1-6**
Frame Designations, **P-2, A-1, B-6**
Fuses
Input, **1-7**
Ratings, **A-1**

G

General Precautions, **P-3**

Ground Fault, **4-3**

Grounding

Filter, **1-6**

General, **1-5**

H

Heatsink OvrTmp Fault, **4-3**

HW OverCurrent Fault, **4-3**

I

I/O

Wiring, **1-13**

Wiring Examples, **1-15, 1-18**

I/O Board Fail Fault, **4-4**

Input Contactor, **1-12**

Input Fusing, **1-7**

Input Potentiometer, **1-15**

Input Power Conditioning, **1-4**

Installation, **1-1**

Integral Keypad, **2-3**

Interference, EMC/RFI, **1-21**

K

Keypad, **2-3**

L

LEDs, **2-3**

M

Minimum Clearances, **1-2**

Motor Cable Length, **1-10**

Motor Overload Fault, **4-3**

Motor Stalled Fault, **4-3**

motor starter, **1-7**

Mounting Options and Clearances, **1-2**

MOVs, **1-3**

O

Opening the Cover, **1-1**

Operating Temperatures, **1-2**

Operator Interface, **2-3**

OverVoltage Fault, **4-3**

P

Parameter

Descriptions, **3-1**

Types, **3-1**

Viewing and Editing, **2-4**

Parameter Checksum Fault, **4-4**

Parameter Cross Reference

by Name, **3-31**

Parameters

Advanced Program Group, **3-19**

Communications Group, **3-17**

Display Group, **3-3**

Program Group, **3-8**

Terminal Block Group, **3-13**

PE Ground, **1-5**

Phase Short Fault, **4-4**

Phase to Ground Fault, **4-4**

Potentiometer, Wiring, **1-15**

Power Cables/Wiring, **1-9**

Power Conditioning, Input, **1-4**

Power Loss Fault, **4-3**

Power Unit Fault, **4-4**

Powering Up the Drive, **2-1, 2-2**

Precautions, General, **P-3**

Product Selection, **B-1**

Program Group Parameters, **3-8**

Programming, **3-1**

PTC Analog Input Wiring, **1-15**

R

Ratings, **A-1**

Reflective Wave Protection, **1-10**

Removing Cover, **1-1**

Repeated Start/Stop, **1-12**

Repeated Start/Stop Precautions, **1-12**

RFI, see *EMC/RFI*

RWR (Reflective Wave Reducer), **1-10**

S

Safety Ground, **1-5**

Shielded Power Cables, **1-10**

Short Circuit Protection, **1-7**

Software, **3-1**

Start and Speed Reference Selection and Control, **1-19, 1-20**

Start/Stop, Repeated, **1-12**

Start-Up Checklist, **2-1, 2-2**

Static Discharge, ESD, **P-3**

Status LEDs, **2-3**

Supply Source, AC, **1-3**

SW OverCurrent Fault, **4-4**

System Grounding, **1-5**

T

Terminal Block

I/O, **1-13**

Power, **1-12**

Terminal Block Group Parameters, **3-13**

Three Wire Control, **1-15, 1-18**

Two Wire Control, **1-15, 1-18**

U

UnderVoltage Fault, **4-3**

Ungrounded Supply, **1-3**

Unshielded Power Cables, **1-9**

W

Watts Loss, **A-5**

Wiring, **1-1**

Block Diagram, **1-14**

I/O, **1-13**

I/O Examples, **1-15, 1-18**

Potentiometer, **1-15**

Power, **1-9**

PTC Example, **1-15**