

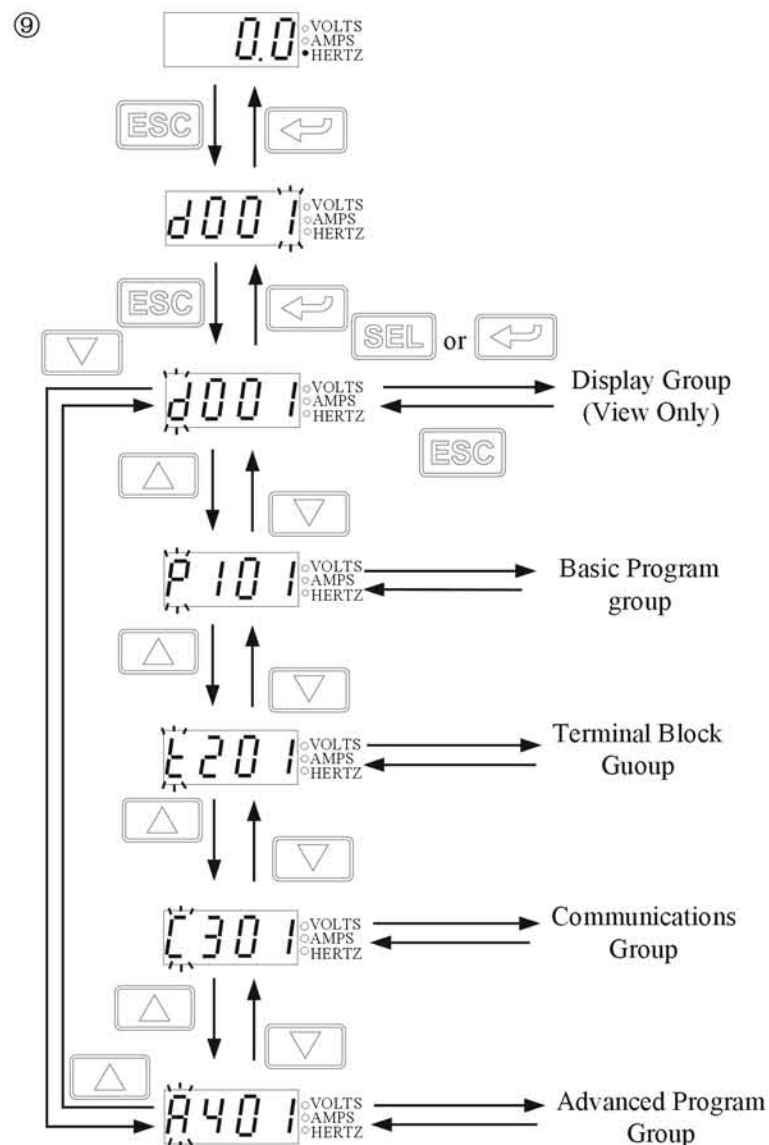

To Navigate Parameter Groups

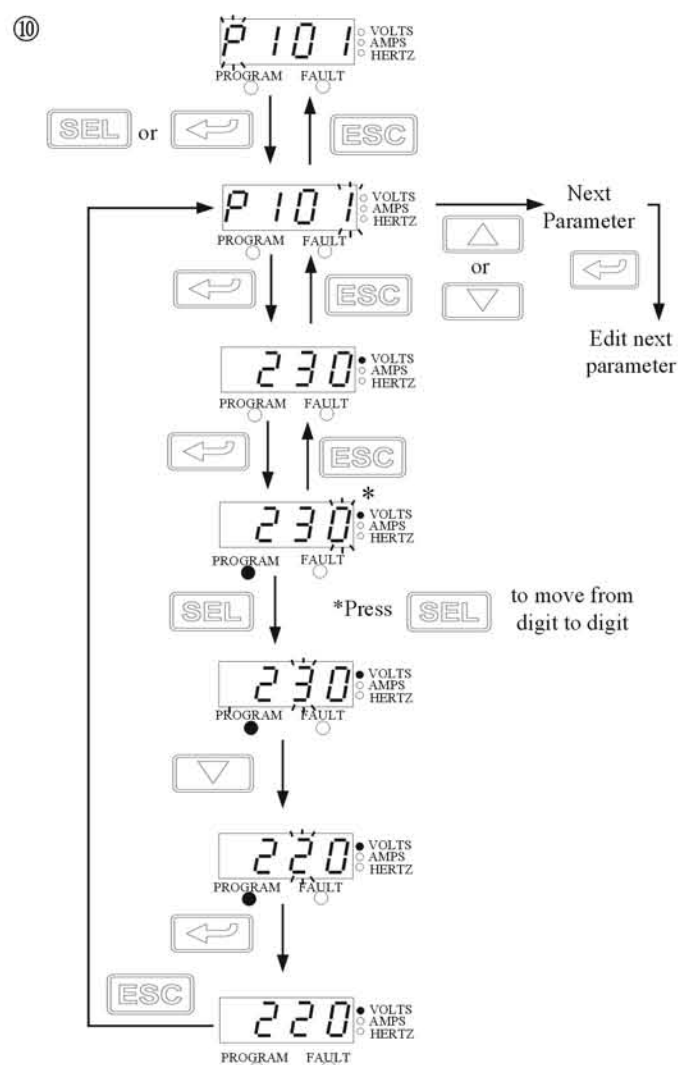

To Change a Parameter Value (Example)



Integral Keypad

No.	LED
①	Run/Direction Status (Red) Note: Flashing means drive has been commanded to change direction. Indicates actual motor direction while decelerating to zero.
②	Alphanumeric Display (Red)
③	Displayed Units (Red)
④	Program Status (Red)
⑤	Fault Status (Red)
⑥	Speed Potentiometer Status (Green)
⑦	Start Key Status (Green)

Key	Name	Key	Name
	Escape		Speed Potentiometer
	Select		Start
	Up Arrow		Reverse
	Down Arrow		Stop
	Enter		

Basic Program Group Parameter

= Stop drive before changing the value of this parameter.

No.	Parameter	Min/Max	Display/Option	Default
P101	[Motor NP Volts] Set to the motor nameplate rated volts.	20/Drive Rated Volts	1VAC	Based on Drive Rating
P102	[Motor NP Hertz] Set to the motor nameplate rated frequency.	10/400Hz	1Hz	60Hz
P103	[Motor OL Current] Set to the maximum allowable motor current.	0.0/(Drive Rated Amps x 2)	0.1Amps	Based on Drive Rating
P104	[Minimum Freq] Sets the lowest frequency the drive will output continuously.	0.0/400.0Hz	0.1Hz	0.0Hz
P105	[Minimum Freq] Sets the highest frequency the drive will output.	0/400Hz	1Hz	60Hz
P106	[Start Source] Sets the control scheme used to start the drive. 1 When active, the Reverse key is also active unless disabled by A434 [Reverse Disable].	0/5	0= "Keypad" 1 1= "3-Wire" 2= "2-Wire" 3= "2-W Lvl Sens" 4= "2-W Hi Speed" 5= "Comm Port"	0
P107	[Stop Mode] Active stop mode of all stop source [e.g. keypad, run forward (I/O terminal 02), run reverse (I/O terminal 03), RS485 port] except as noted below. Important: I/O Terminal 01 is always a coast to stop input except when p106 [Start Source] is set for "3-Wire" control. When in three wire control, I/O Terminal 01 is controlled by P107 [Stop Mode]. 1 Stop input also clears active fault.	0/7	0= "Ramp, CF" 1 1= "Coast, CF" 1 2= "DC Brake, CF" 1 3= "DC Brake Auto, CF" 1 4= "Ramp" 5= "Coast" 6= "Dc Brake" 7= "DC Brake Auto"	0
P108	[Speed Reference] Important: When t201 or t202 [Digital Inx Sel] is set to option 2, 4, 5, 6, 13 or 14, and the digital input is active, t201 or t202 will override the speed reference commanded by this parameter. Reference commanded by this parameter. Refer to Chapter 1 of the HPVFE User Manual for details.	0/5	0= "Drive Pot" 1= "Internal Freq" 2= "0-10V Input" 3= "4-20mA Input" 4= "Preset Freq" 5= "Comm Port"	0
P109	[Accel Time 1] Sets the rate of acceleration for all speed increases.	0.0/600.0Secs	0.1Secs	10.0Secs
P110	[Decel Time 1] Sets the rate of deceleration for all speed increases.	0.1/600.0Secs	0.1Secs	10.0Secs
P111	[Motor OL Ret] Enables/disables the Motor Overload Retention function.	0/1	0= "Disabled" 1= "Enabled"	0
P112	[Reset To Defaults] Resets all parameter values to factory defaults.	0/1	0= "Idle State" 1= "Reset Default"	0

Fault Codes

F is the fault designator.

To clear a fault, press Stop , cycle power or set A450 [Fault Clear] to 1 or 2. For details on fault codes, refer to the User Manual.

No.	Fault	No.	Fault
F2	Auxiliary ⁽¹⁾	F40	Phase W to Gnd
F3	Power Loss	F41	Phase UV Short
F4	UnderVoltage ⁽¹⁾	F42	Phase UW Short
F5	OverVoltage ⁽¹⁾	F43	Phase VW Short
F6	MotorStalled ⁽¹⁾	F48	Params Defaulted
F7	Motor Overload ⁽¹⁾	F63	SW OverCurrent ⁽¹⁾
F8	Heatsink OvrTmp ⁽¹⁾	F64	Drive Overload
F12	HW OverCurrent	F70	Power Unit
F13	Ground Fault	F71	Net Loss
F33	Auto Rstrt Tries	F81	Comm Loss
F38	Phase U to Gnd	F100	Parameter Checksum
F39	Phase V to Gnd	F122	I/O Board Fail

(1) Auto-Reset/Run type fault. Configure with parameter A451 and A452.

①

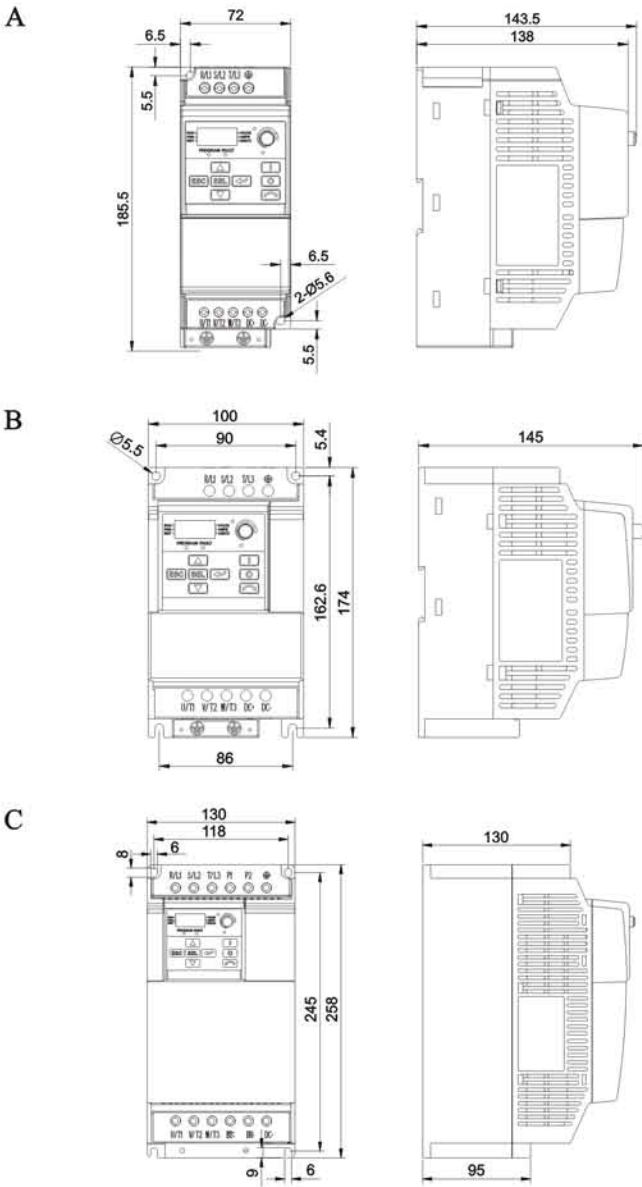

②

Frame	240V AC 1-Phase	240V AC 3-Phase	480V AC 3-Phase
A	0.2kW (0.25HP) 0.4kW (0.5HP) 0.75kW (1.0HP)	0.2kW (0.25HP) 0.4kW (0.5HP) 0.75kW (1.0HP) 1.5kW (2.0HP)	0.4kW (0.5HP) 0.75kW (1.0HP) 1.5kW (2.0HP)
B	1.5kW (2.0HP) 2.2kW (3.0HP)	2.2kW (3.0HP) 3.7kW (5.0HP)	2.2kW (3.0HP) 3.7kW (5.0HP)
C	—	5.5kW (7.5HP) 7.5kW (10.0HP)	5.5kW (7.5HP) 7.5kW (10.0HP) 11.0kW (15.0HP)

③

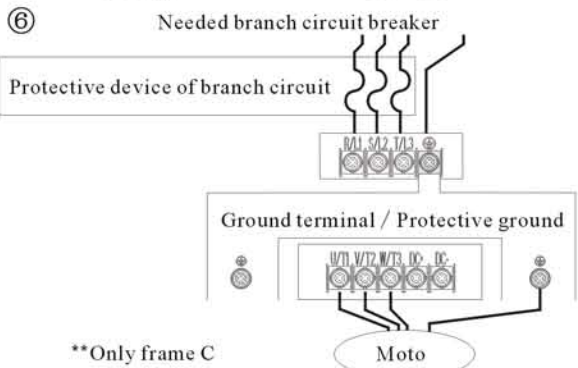
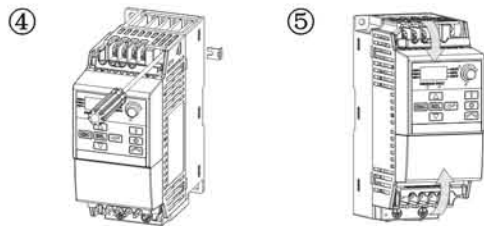
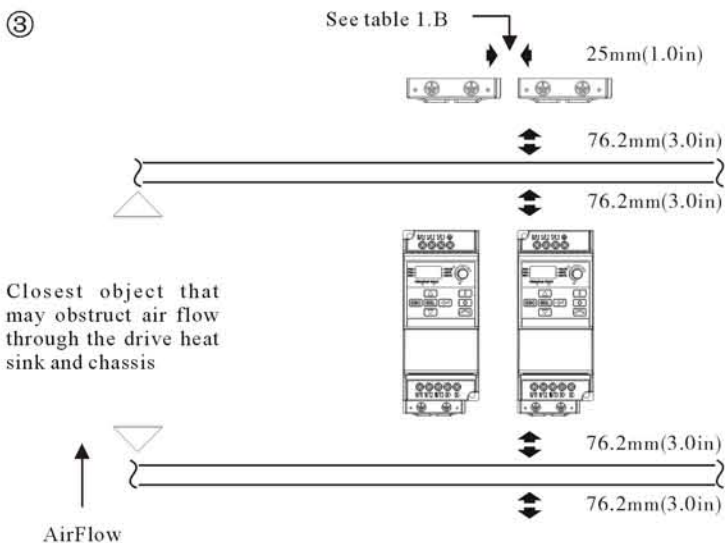

**Only frame C

English

This Quick Start will guide you through basic installation, wiring and basic parameter setup of the HPVFE Adjustable Frequency AC Drive. After completing these tasks, you will be able to start the motor, check direction of rotation and control speed using the integral keypad and potentiometer. **The information provided does not replace the user Manual and is intended for qualified drive service personnel only.**

This document does not provide instructions for grounding, shield, control I/O, ESD or CE conformity. Refer to the HPVFE user manual at <http://www.hapn.com>.

⚠ General Precautions

ATTENTION: You must understand shock hazards, safety practices, election codes and associated machinery to plan or implement the installation, start-up and maintenance of this drive. Failure to comply may result in personal injury and/or equipment damage.

ATTENTION: The drive contains high voltage capacitors which take time to discharge after removal of main supply. Before working on drive, ensure isolation of mains supply from line inputs[R, S, T(L1, L2, L3)]. Wait three minutes for capacitors to discharge to safe voltage levels. Failure to do so may result in personal injury or death. Darkened display LEDs is not an indication that capacitors have discharge to safe voltage levels.

ATTENTION: Equipment damage and/or personal injury may result if parameter A451 [Auto Rstrt Tries] or A433 [Start At PowerUp] is used in an inappropriate application. Do not use this function without considering applicable local, national and international codes, standards, regulation or industry guidelines.

See Figure ① and Table ②. Ratings are in kW and (PH). Dimensions are in millimeters and (inches). Weights are in kilograms and (pounds). Decimal periods are used in this document.

*DIN rail mounting is applicable to Frame A and B only.

1. Installation must comply with minimum clearances and ambient temperature. Mount upright on a flat vertical surface with screws or a DIN rail. See Figure ? and the following table.

Horizontal Clearance between drives	Ambient Temperature	
	Minimum	Maximum
0mm and greater	-10°C (14°F)	40°C (104°F)
25mm and greater	-10°C (14°F)	50°C (122°F)

Drive enclosure is rated IP20, NEMA/UL Type Open.

2. The MOV to ground jumper must be removed if the drive is installed on an ungrounded or resistive grounded distribution system. (Figure ④)

Important: Tighten screw after jumper removal.

3. Open the finger guards to assess the power terminal blocks. (Figure ⑤)

Important: Connecting remote devices to the control terminals (Figure ⑦) requires information in the User Manual. Terminal functions must be configured with related parameters. Proceed to Step 4 if you want to start the motor using the integral keypad.

4. Connect the power wires. (Figure⑥and Table ⑧)
5. Connect the load from motor. Prepare to check for correct rotation of the motor.
6. Check all wiring done in Step 4.
7. Close branch circuit disconnect to apply power.

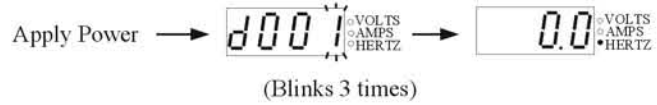

If a fault code (Fxxx) is displayed instead, see the Fault Codes section on the next page.

8. Adjust the Speed Potentiometer according to your application.
9. Press Start and verify that the motor rotation is correct. (Table⑧)
10. Press Stop . Disconnect power.
11. Refer to the User Manual to wire control I/O terminal block or program parameters to achieve desired functionality. See the next page to program Basic Program group parameters.

⑦

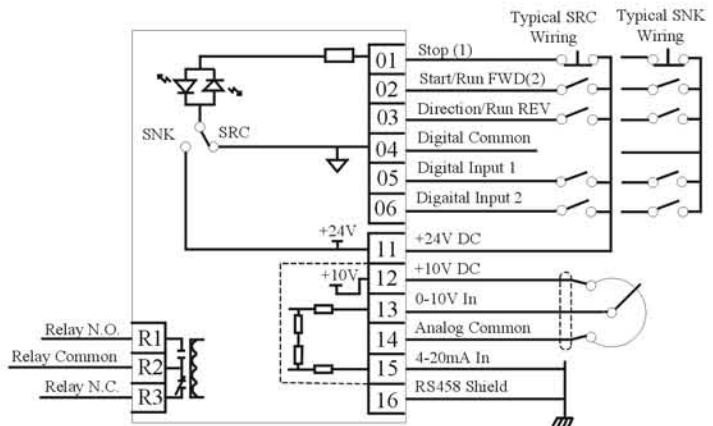

⑧

Terminal	Description	
R/L1, S/L2	1- Phase Input	
R/L1, S/L2, T/L3	3- Phase Input	
P1, P2	DC Bus Inductor Connection ⁽¹⁾	
U/T1	To Motor U/T1	Switch any two motor leads to change forward direction
V/T2	To Motor V/T2	
W/T3	To Motor W/T3	
DC+, DC-	DC Bus Connection	
BR+, BR-	Dynamic Brake Resistor Connection ⁽¹⁾	
	Safety Ground-PE	

(1) For Frame C only [5.5kW (7.5HP)] rating and higher.